

Packaging Guideline Non Food

For Primary, Secondary and
Tertiary Packaging

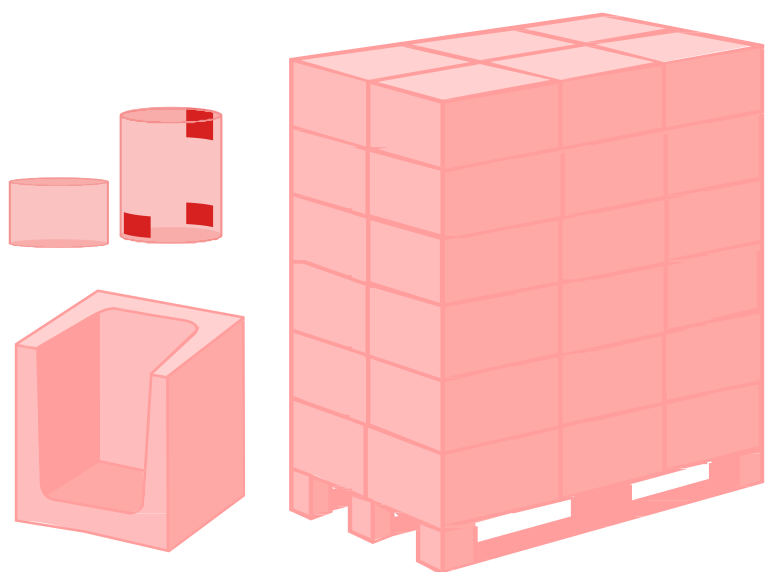

Table of Contents

Table of Contents	1
History of amendments	4
I. Basic concept of the packaging guideline	5
II. Scope of application	5
III. Definitions	7
IV. Decision tree for the requirements of packaging units	7
1 Requirements for primary packaging	9
1.1 Basic requirements	9
1.1.1 More sustainable primary packaging of REWE Group own-brand products	9
1.1.2 Requirements for certified paper packaging (FSC/PEFC) primary packaging	10
1.1.3 Item protection	10
1.1.4 Closure and anti-theft protection	10
1.1.5 Polybags.....	11
1.1.6 Euro-standard holes	11
1.2 Labelling requirements	12
1.2.1 Statutory obligations	12
1.2.2 Labelling of materials used.....	12
1.2.3 Labelling of sales packaging with PLUs.....	13
1.2.4 Contact address.....	14
1.2.5 Country of origin.....	15
1.2.6 Languages	15
1.3 Requirements for barcodes	15
1.3.1 Size and number	15
1.3.2 Placement.....	15
1.3.3 Design and content.....	17
1.3.4 Colour and contrast.....	17
1.3.5 Print quality	17
1.4 Primary packaging as transport unit	17
2 Requirements for secondary packaging	18
2.1 Logistical requirements	18
2.1.1 Protection, stability, stackability	18
2.1.2 Gluing and perforation	18
2.1.3 Plastic film	19
2.1.4 Weight	19
2.1.5 Dimensions	20

2.1.6	Display and tray cartons on the lattice table	20
2.1.7	Bottom, cover, handles and handholds	20
2.2	Functional requirements.....	21
2.2.1	Easy identification	21
2.2.2	Easy opening.....	22
2.2.3	Straightforward placement	23
2.2.4	Easy shopping.....	24
2.2.5	Easy disposal.....	24
2.3	Secondary packaging as transport unit	25
3	Requirements for tertiary packaging	26
3.1	Requirements for master cartons	26
3.1.1	Definition and purpose.....	26
3.1.2	Types.....	26
3.1.3	Dimensions	26
3.1.4	Labelling.....	26
3.1.5	Easy disposal.....	27
3.2	Requirements for Euro pallets.....	27
3.2.1	General requirements	27
3.2.2	Optimal pallet utilisation.....	28
3.2.3	Height and weight of the loading unit.....	29
3.2.4	Layer form	30
3.2.5	Load securing.....	31
3.2.6	Composite stacking	33
3.2.7	Identification / labelling of the pallet.....	33
3.2.8	Label attachment and positioning.....	36
4	Requirements for transport units	38
4.1	Definition and delimitation	38
4.2	Carton strength	38
4.3	Closure.....	38
4.4	Weight	39
4.5	Handling labelling.....	39
4.6	Bottom, corners and walls	40
4.6.1	Transport units with window cut-outs.....	40
4.6.2	Two-part transport units.....	41
4.7	Use of filler materials.....	41
4.8	Stability testing	41
4.8.1	Vertical impact test (DIN EN 22248).....	41
4.8.2	Stacking test (in accordance with DIN EN 22872)	42

4.8.3	Climate test	42
4.8.4	Vibration test (DIN EN 22247)	43
5	Import-specific requirements	43
5.1	Optimisation of the packaging dimensions of a transport unit	43
5.2	Loading and load securing.....	44
5.3	Use of wood packaging material	44
5.4	Packaging wood from China	44
Annex 1: Barcode specifications per packaging type		46
Annex 2: Specified goods pursuant to Implementing Decision 2013/92/EU		53

History of amendments

Version	Date	Type of amendment and commentary
3.0	01.09.2023	<p>1.1.4 Closure and anti-theft protection Permanent self-adhesive labels (circular) must not be stuck over the packaging tabs of folding cartons</p> <p>1.1.5 Polybags Addition of German translation to suffocation alert. All textile articles must not be supplied vacuumed as a matter of principle. Vacuumed articles may only be vacuumed after consultation with the purchasing department.</p> <p>1.2.4 Contact Address Change of name from REWE - Zentral AG to REWE - Zentral GmbH</p> <p>2.1.2 Glueing and Perforation Added an exception to the use of stickers on the floor.</p> <p>2.1.5 Dimensions Permissible dimensions 400x400mm added.</p> <p>2.2.1 Easy Identification Addition of a labeling example including additional information</p> <p>2.2.2 Easy Opening Full-surface inserts may also be used to protect the product.</p> <p>3.1.4 Labelling Requirement for labeling of the master carton added including addition of a labeling example and notes.</p> <p>5.2 Loading and Load Securing Specification of the requirements.</p> <p>5.3 Use of wood packaging material Added further requirements for the case an item must be heat treated or fumigated.</p>

I. Basic concept of the packaging guideline

- The packaging guideline is a key document that regulates the relevant optical and physical properties of the various types of packaging.
- The aim is to optimise the flow of goods across all parts of the supply chain.
- In order to achieve this, the packaging guideline has to take into account both the logistical requirements during transport and for secure and efficient picking, as well as the functional requirements of the market for smooth goods handling and optimum marketability.
- The implementation of this guideline in terms of optimised goods flow is the shared responsibility of all participants in the supply chain.
- Single-use material is preferred for all types of transport, protective and outer packaging.
- PVC must not be used for packaging materials or packaging components.

II. Scope of application

- The packaging guideline for primary, secondary and tertiary packaging applies to all Non Food items.
- Deviating regulations specific to particular sales channels and product categories are named and marked with the following symbol:

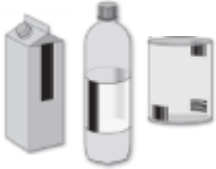
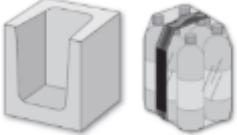
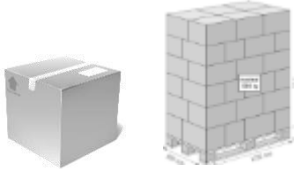

- Specific requirements can apply, depending on their allocation to a strategic business units (SBU), e.g. REWE, Penny supermarkets or toom Baumarkt. These requirements must be complied with and can be found in their respective manuals, packaging specifications or own brand style guides. The additional requirements can be obtained from the respective REWE Group contact person.
- In addition, there can also be individually agreed specifications relating to a particular project, order or product. These could come from Purchasing, Category Management and / or Quality Management, and must also be complied with.
- Please note that the content of this guideline does not release the executing company in any way from its liability for losses caused by for example, defective packaging or the lack of safe and appropriate packaging properties. The executing company has a duty to notify the REWE Group regarding all changes in its packaging.
- The chapter on primary packaging regulates all optical properties of primary packaging that are relevant for Barcode scanning (packaging of the items themselves) as well as all basic requirements for primary packaging.
- The chapters on secondary and tertiary packaging regulate all the optical and physical properties of secondary packaging (packages, trays) or tertiary packaging (transport cartons, pallets) that are relevant for the optimal flow of goods.
- The chapter on transport units regulates all the optical and physical properties of the transport unit, i.e. the handling unit for optimal goods flow, regardless of the packaging level (primary, secondary, tertiary).
- The chapter on import-specific requirements defines the requirements for imports into Germany from countries outside the EU.

	Optical characteristics	Physical characteristics
<p>Primary packaging (items)</p> 	<p>Requirements for primary packaging</p>	
<p>Secondary packaging (package, tray)</p> 	<p>Requirements for secondary packaging</p>	
<p>Tertiary packaging (master carton, pallet)</p> 	<p>Requirements for tertiary packaging</p>	

III. Definitions

Packaging in the REWE Group is divided into 3 hierarchy levels:

- Primary packaging
- Secondary packaging
- Tertiary packaging

Generally speaking, the primary packaging corresponds to the sales unit, i.e. the unit that the end customer/consumer buys in the store.

The secondary packaging combines several items of primary packaging, e.g. in a package or tray or a display, and can also be used for presentation purposes in the market. It usually corresponds to the ordering unit, and is also referred to as a shipping unit (VE).

The tertiary packaging is a purely logistical unit. It bundles together several secondary packages, either in a master carton (outer carton around several secondary packages) and/or on a pallet, and is therefore usually broken up in the logistics warehouse before being distributed to the stores.

In addition to the hierarchy levels, there is the transport unit. This refers to the outermost packaging level regardless of hierarchy, and corresponds to the handling unit used by the supplier for transport to the REWE Group. A transport unit can thus be primary, secondary or tertiary packaging.

IV. Decision tree for the requirements of packaging units

The following decision tree is designed to help you identify the applicable requirements for your packaging combination. It is read from top to bottom and guides you through a series of questions to the relevant chapters for each case.

Please note, that the use of this decision tree is not a substitute for the correct and complete application of all applicable requirements.

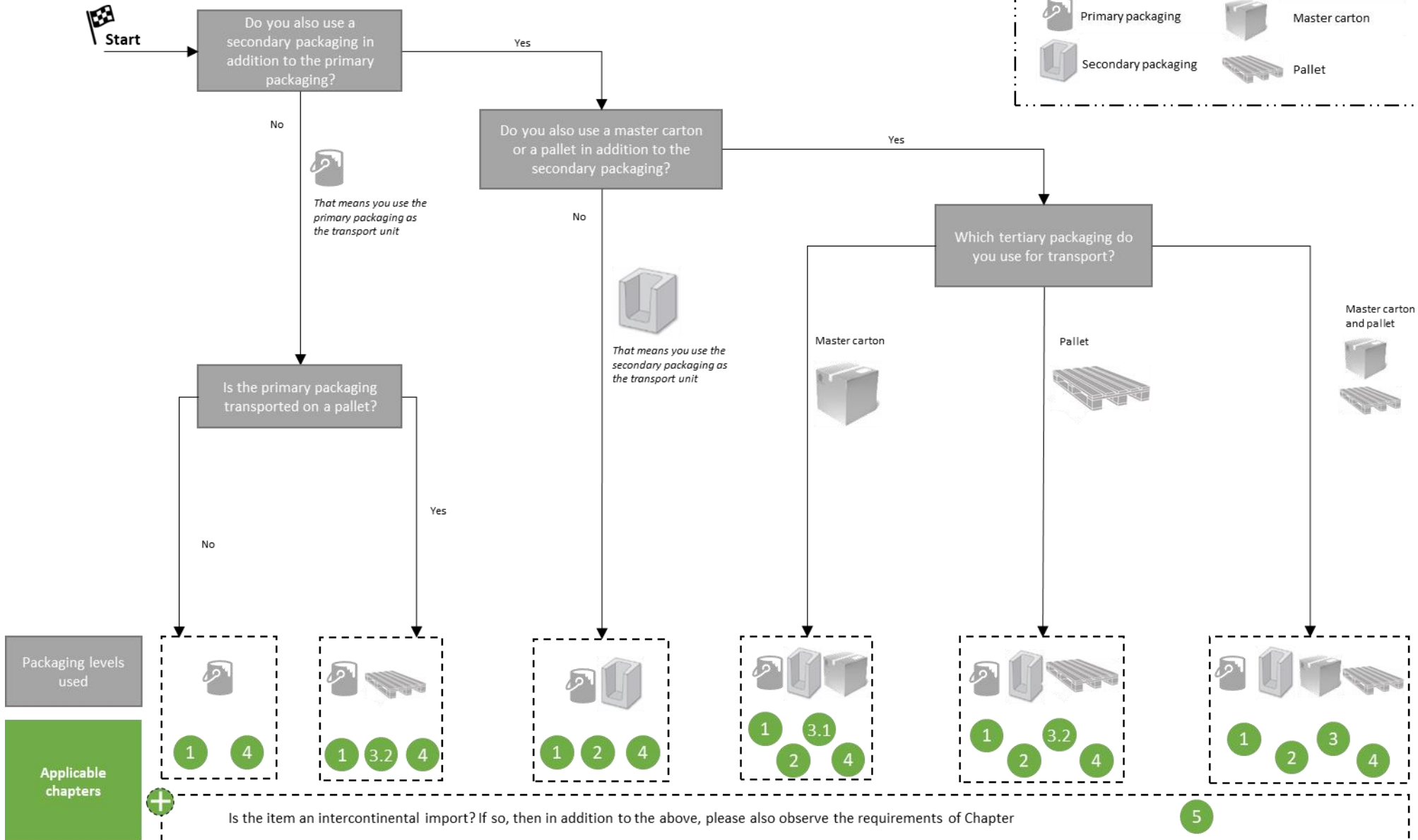

1 Requirements for primary packaging

1.1 Basic requirements

The primary packaging contains the item and is usually the sales packaging in the store. The possible forms and components of primary packaging are defined in the German Packaging Act ([Section 3 \(1\) “Definitions”](#) and the corresponding [Annex 1 “Criteria for definition”](#)).

REWE Group maintains the following basic requirements for primary packaging:

- Priority should be given to packaging in accordance with the FEFCO catalogue.
- The latest version of the FEFCO catalogue (www.fefco.org) serves as a guideline for the types of sales packaging.
- Deviating packaging is possible in consultation with (and subsequent to written approval by) the responsible REWE Group contact person.
- Tuck-in flaps with locking tabs are preferred.
- Wire stitching is not permitted.
- Depending on the project, the boxes used can be supplemented by viewing windows and/or suspension options or carrying handles.
- In coordination with the respective contact person of REWE Group, a carrying option should also be provided with the packaging for a total weight in excess of 7 kg (item including packaging) and / or an edge length in excess of 50 cm.
- All representations and claims on the sales packaging must correspond to the assured characteristics laid out in the European or country-specific obligation to submit a binding declaration.
- The distributor named on the packaging will be specified by the respective REWE Group contact person. Any reference to the distributor on the sales packaging shall require the written approval of REWE Group contact person.

1.1.1 More sustainable primary packaging of REWE Group own-brand products

- The REWE Group is aiming to implement 100 per cent more sustainable own-brand packaging by the end of 2030.
- “More sustainable packaging” is defined as having a positive effect on the environment, by **avoiding, reducing or improving** the packaging material.
- The strategy, criteria and further information can be found on the [REWE Supplier Portal](#) (under the topic “Information” > “Sustainability” you can find the Guideline for Eco-Friendly Packaging as well as the Dos & Don’ts for Eco-Friendly Packaging).
- To effectively achieve this goal, our suppliers are asked to participate proactively and collaboratively in the design of sustainable primary packaging.
- Compliance with the requirements of this document (Non Food Packaging Guideline) must still be followed.

The following is an extract from the relevant requirements for the design of more sustainable primary packaging:

- The greatest possible avoidance and reduction of packaging material is an important goal. For this reason that we expect our suppliers to use the least possible packaging material when designing and manufacturing the primary packaging of own-label items.
- This also applies to the material that is used to protect the item inside the primary packaging. It must be reduced to a minimum without compromising the protection of the item.
- The use of bioplastics is currently not recommended.

- Where possible, the packaging should consist of a single material, in order to maximise the recyclability of the packaging. This must be decided in consultation with your REWE Group contact person.
- The use of recycled raw materials is generally to be preferred to the use of virgin materials. However, the product-specific requirements must be taken into consideration and agreed with the REWE Group contact person.
- The use of plastics dyed with carbon black is not permitted.

1.1.2 Requirements for certified paper packaging (FSC/PEFC) primary packaging

- All paper packaging of REWE Group own-label items must be FSC or PEFC-certified
- This applies for a primary packaging when paper components (including for example, paper inlays, banderoles, hang tags, wrapping paper) comprise more than 30% of the total primary packaging.
- The manufacturer is responsible for ensuring that only the correct FSC or PEFC certificates are used. The FSC or PEFC certificate number must be put on to the packaging by the supplier (invoicing party to REWE) itself or by the pre-supplier, who was the last to significantly change the packaging (usually the printing company).
- Further details can be found in the “REWE Group – Our Sustainability Requirements for Non Food Suppliers” in the REWE supplier portal ([Link](#)) under the topic “Information” > “Sustainability”.

1.1.3 Item protection

- Item protection options include polybags, tissue paper, die-cut or corrugated cardboard inserts, as well as fibre-moulded padding.
- Sharp-edged items and / or articles with sharp components shall be provided with sufficient additional protection, or protection that prevents injury or puncturing of the packaging.
- Plastic films or polybags should only be used where they are necessary. As far as possible, the aim should be to eliminate plastic materials or to reduce plastic to a minimum.
- Alternative options for item protection should be considered, such as thin paper separators or biomass materials.



Fig. 1 Example of plastic film as additional item protection



In exceptional cases, in the **toom Baumarkt** distribution channel Styrofoam® (expanded polystyrene) may be used to protect the item, including heavy items such as toilet seats. If Styrofoam® is used it must be accompanied by a chemical report.

1.1.4 Closure and anti-theft protection

- Packaging should generally be sealed so that it is impossible to remove the goods without damaging the closure seal or the packaging. Exceptions are only permitted with the agreement of our REWE Group contact person.

! Paper inserts in pans are an exception. The packaging can be removed without damage, but must remain securely on the product during normal handling (e.g. shaking).

- Only permanent self-adhesive labels (circular) made of plastic and with a diameter of at least 30 mm should be used as the closure seal. On packaging with a glued-on blister or an opening /side length of 40 mm or less, permanent self-adhesive labels (circular) made of plastic with a minimum diameter of 15 mm must be used.
- Permanent self-adhesive labels (circular) must not be stuck over the packaging tabs of folding cartons

! An exception **only applies to polybags for textile articles**: the packaging must be sealed in such a way that it is possible to open and close the polybag without damaging the closure seal and packaging.

1.1.5 Polybags

- All bags in use are transparent or clear.
- The minimum film thickness that is used is 40 µm.

! For textile items, the minimum film thickness used is **80 µm**.

- All textile articles must not be supplied vacuumed as a matter of principle. Vacuumed articles may only be vacuumed after consultation with the purchasing department.
- If the bag opening is greater than 19 cm or the opening size is greater than 38 cm, the bags must have suitable air hole perforations to avoid suffocation. In addition, the following warning (or texts with comparable content) must be printed on the film:
ACHTUNG: Erstickungsgefahr: Dieses Verpackungsmaterial von Babys, Kleinkindern und Kindern fernhalten. / **WARNING:** Danger of suffocation: Keep this bag away from babies and children.
- Typical materials are PE and PP.
- PVC must not be used.

! To prevent the ingress of contamination and moisture, no holes are permitted in the polybag for **items in contact with food**.

1.1.6 Euro-standard holes

If REWE Group specifies that the sales packaging should have Euro-standard holes, these must be punched out in accordance with the European standard specified in DIN EN 13010 (see Fig. 2), unless the REWE Group contact person specifies any deviating Euro hole dimensions. Deviating tolerances are regulated in the above-mentioned DIN standard.

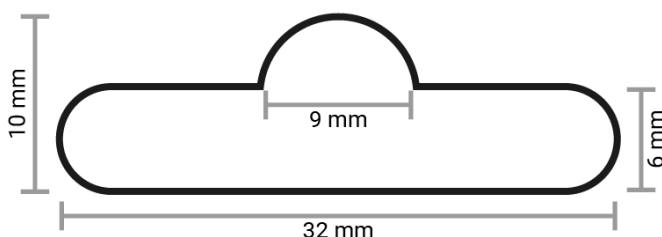

Fig. 2: Euro hole dimensions in accordance with DIN EN 13010



The following perforations diverge from the above Euro perforations and only apply to items for **toom Baumarkt** stores.

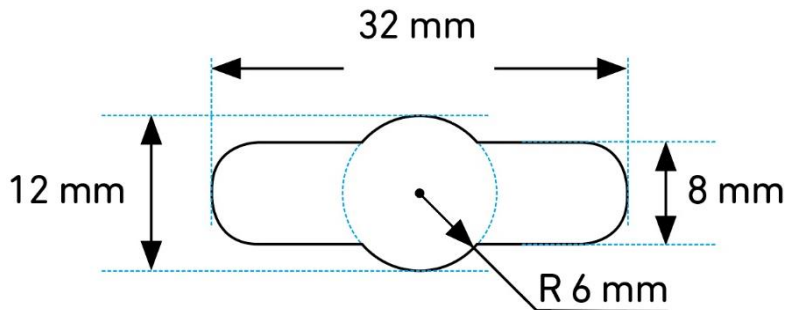

Fig. 3: Euro perforation dimensions **only for toom Baumarkt**

1.2 Labelling requirements

The requirements for the labelling of primary packaging are defined below.

1.2.1 Statutory obligations

EU directives and /or packaging regulations in relation to product labelling, packaging, and the operating instructions must be observed. In addition, the following REWE-specific requirements apply.

1.2.2 Labelling of materials used

All materials in use must be marked with the recycling symbol in accordance with their composition and corresponding material code. However, in exceptional cases it is not necessary to print the recycling symbol on the material (e.g. small-format materials, materials without any other printing)

The following table provides an overview of the key materials and their recycling symbols; this list makes no claim to being complete.









Number	Abbreviation	Name of material
 01 PET	PET	Polyethylene terephthalate
 02 PE-HD	HDPE	High density polyethylene
 04 PE-LD	LDPE	Low density polyethylene
 05 PP	PP	Polypropylene
 06 PS	PS	Polystyrene
 20 PAP	PAP	Corrugated cardboard
 21 PAP	PAP	Other cardboard
 22 PAP	PAP	Paper

Table 1: Numbers and abbreviations for plastics, paper and cardboard (Source: Federal Ministry for the Environment, Nature Conservation and Nuclear Safety - Packaging Ordinance)

1.2.3 Labelling of sales packaging with PLUs

! For the REWE and Penny sales channels, PLU numbers can be used in consultation with the REWE Group contact person. The following requirements apply here:

- Packaging must have a PLU number if the shortest or narrowest side is longer or wider than 40 cm or if it weighs more than 10 kg. The PLU number must be printed in at least two easily visible places (front and back) on the packaging.
- The box size should vary in proportion to the size of the package, but not be smaller than 40 mm high.
- The PLU number can be obtained from our respective REWE Group contact person.

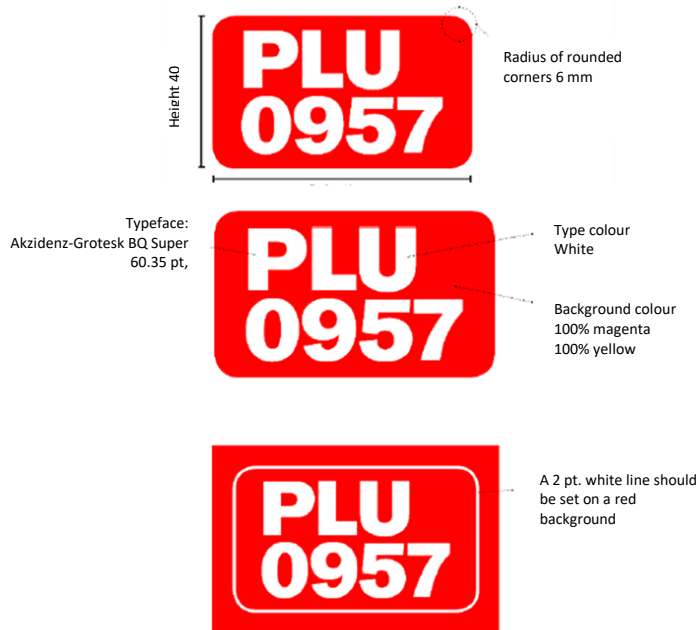

Fig. 4: PLU

1.2.4 Contact address

The details defined below apply unless otherwise agreed with our REWE Group contact person.

RZAG is defined as a distributor

- The following address is specified for all countries as the manufacturer's information on the product, the packaging and the operating instructions.
- The post code is preceded by the country code "D".
- The street name is not required as REWE Group has its own bulk recipient postcode, which includes the street name.

REWE - Zentral GmbH
D - 50603 Köln

RZAG is defined as a distributor:

- The following address is specified for all countries as the manufacturer's information on the product, the packaging and the operating instructions.

European manufacturer's name
Street and building number
Country code – Postcode and city

- The postcode is preceded by the manufacturer's country code e.g. "D" for Germany.

1.2.5 Country of origin

In principal, there should be no declaration indicating "Made in ..." on the product, the packaging and the operating instructions. Any exceptions will be specified by our REWE Group contact person.

1.2.6 Languages

Product name and sales information

The customer must be able to make an individual decision to buy based on the information on the product. Statutory markings and warning information must always be in the language of the destination country/countries. If the intended use of the product is not recognisable to the customer, a product illustration or product name must be present. Further promotional features are possible in the language of the destination country/countries, depending on the nature and size of the product or packaging. This must be decided individually according to the product.

Operating instructions and additional warnings

The operating instructions and warning information must always be in the language of the destination country/countries. Should problems arise in implementation and legibility due to the design or size of the product, decisions must be taken in consultation with our REWE Group contact person on an individual case basis.

1.3 Requirements for barcodes

1.3.1 Size and number

- Essentially, the barcode must be integrated into the packaging design in such a way that the visual appearance of the packaging is in no way impaired.
- If possible, a barcode should be placed on each side of the packaging (not on the front wherever possible) to obtain the best possible scan rates.
- Packaging without a multiple barcode is only permitted in absolute exceptional cases and after prior written approval by the responsible contact person of REWE Group.
- The number of barcodes is more important than the size of the barcodes.
- Essentially, barcodes of size SC2 (uncut) are optimal and preferable to all smaller barcodes.
- Instead of reducing (scaling) a larger barcode as a whole, wherever possible the height should be reduced (see also Section 1.3.3).
 - A shortened bar code of size SC2 is preferable to a barcode of size SC1.
 - Similarly, a shortened barcode of size SC1 is preferable to an uncut barcode of size SC0.
 - Essentially, the smaller the size of the barcode, the higher the requirements for print quality (see Section 1.3.5).

1.3.2 Placement

- Generally speaking, a diagonally offset arrangement is preferable - particularly if not all sides can accommodate a barcode.

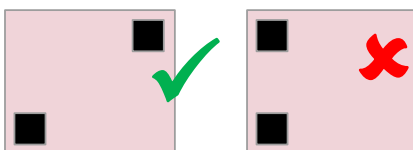

Fig. 5: Diagonal arrangement

- For large packages (from 40 cm depth / edge length upwards) NO diagonal arrangement should be made, as this bears the risk of double scans.



Fig. 6: Recommended barcode placement for large items

- The correct barcode placement ensures that each item can be slid over the scanner in any position, and at least one barcode will be recorded.
- The optimal placement of barcodes depends on the type of packaging used for the respective article. Specifications for each form of packaging are laid out in Annex 1.
- Packaging, which is not explicitly described in Annex 1 must be designed in line with the next best type of packaging, and must facilitate optimum scanning.
- If the product is not suitable for scanning via the cash register conveyor belt due to its dimensions (weight, volume, size), alternatives must be arranged for the cashier process (cf Section 1.2.3).
- Barcodes should be applied as tightly as possible to the edge of a packaging (not applied to perforations, seams, cuts, punches, burrs, creases, overlaps, injection points or ragged fabrics).
- For round bodies (cups, cans, etc.), the following applies in principle:
 - The angle between the outer edges of a fence barcode may not exceed 60 °.
 - If the barcode is wider, a ladder barcode must be attached.

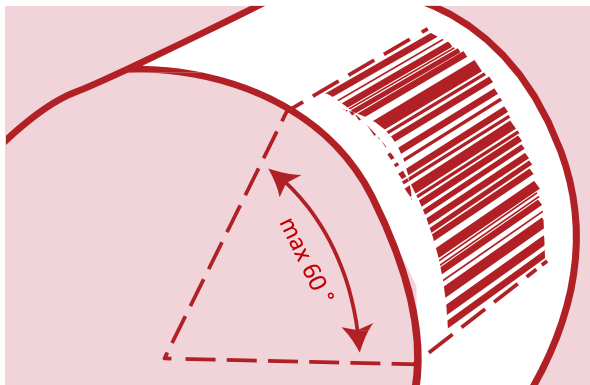

Fig. 7: Limitation of fence barcodes for round shapes (Source: GS1 Austria barcode quality)

- Should the space for additional barcodes on the existing packaging sides become limited, the following declaration elements must not be omitted in favour of the barcode:
 - All information required by law (e.g. article name, filling quantity, distributor and batch number)
 - Warehousing and storage instructions as well as instructions for use
 - Added value symbols and logos: Protected geographical indication, ProPlanet, TÜV Seal, etc.
 - Product added value
 - Texts, where these are an integral part of brand communication
- The following components may be omitted or reduced in favour of another barcode:
 - Marketing texts and other claims (filler texts, e.g. tips & tricks)
 - Additional repetition of the own brand logo
 - Additional repetition of the product name
 - Additional repetition of the product image

1.3.3 Design and content

- A barcode in EAN 13 format should be used, which represents the article number (GTIN = Global Trade Item Number) in a scannable format. Further information about the globally recognised barcode standard can be found at www.gs1.org
- One barcode per primary packaging must be marked with the 13- or 8-digit numerical sequence (GTIN).



In exceptional cases, **Penny** may use an 8-digit barcode after consultation with the respective REWE Group contact person.

- Similarly, the NAN (= REWE-specific article number) and if applicable, the WaWi supplier number (= REWE-specific supplier number) should be printed on it near the barcode. The NAN and WaWi numbers do not have to be underneath the barcode; they can also appear to the top left or right of the barcode (Note: maintain the quiet zone of the barcode!).
- The barcode with GTIN, NAN and, if applicable, the WaWi supplier number must always be printed on the back of the primary packaging.
- The other barcodes do not require a number sequence.
- In exceptional cases, e.g. if placed on the front, these other barcodes may be shortened by up to 1/3.
- In the event of a reduction, sufficient print quality is mandatory (see Section 1.3.5).

1.3.4 Colour and contrast

- The barcode must be created from a solid colour (black or Pantone spot colour).
- Further line colours include e.g. dark green, dark brown or dark blue.
- The preferred background colour is white. Alternatives must follow the GS-1 policies (e.g., light grey, beige, orange, pink, red).

1.3.5 Print quality

- The better the print quality, the faster and more secure the barcode will be decoded.
- A sufficient barcode test result must be guaranteed in any case.
- Specification by REWE Group for the test result: quality level must be at least grade 3 (ANSI grade B) or higher in accordance with CEN / ANSI ISO / IEC 15416 (analogous to GS1 recommendation).
- The specifications of the GS1 guideline on print quality must be observed.

1.4 Primary packaging as transport unit

The primary packaging can also be the transport unit. In this case, the requirements for transport units must be observed (see Section 4).

In addition, the following rules apply to primary packaging used as a transport unit:

- Unless otherwise specified in the own-brand style guide, a minimum of a 4-colour design plus protective coating must be applied on white cardboard to meet the requirements of transport units.
- If, in exceptional cases, the REWE Group contact person accepts in writing a multi-coloured sticker on a brown carton instead of a multi-coloured print, the size, number and position must be determined by the responsible contact person.



Brown cartons will not be accepted as primary packaging for the **REWE** and **PENNY** sales channel.



To protect the white cartons, **VIVESS** own-brand primary packaging must not be used as a transport unit, but must always be transported in a secondary packaging.

2 Requirements for secondary packaging

2.1 Logistical requirements

2.1.1 Protection, stability, stackability

The secondary packaging must protect the goods against mechanical and physical stress of any kind and facilitate their transport and storage over the entire supply chain through the warehouse and on to the point of sale (POS). In the case of contradictory requirements from the POS and logistics regarding secondary packaging, the demands of the stores regarding the requirements of logistics must be met.

All of the following points are essential to efficient warehouse processes:

- Secondary packaging encloses the sales units in such a way that their removal or falling out is prevented when the packaging is closed.
- The secondary packaging should have stable and buckling-resistant edges, which ensure stability and also allow the packages to be stacked on top of each other.
- Cardboard boxes with stacking corners are preferable.
- A tray cut-out section is ideally U-shaped with a carded décollété which prevents the cardboard from fraying.
- In order to prevent the products from falling out, slip-on lids should be used or, in the case of trays, the height of the side wall should be at least 30% of the product height, but generally not less than 40 mm.
- The tray can also be designed individually for each item, depending on the type of placement. This must be agreed with the contact person of REWE Group.
- The packaging should be easy to grasp, e.g. with openings that enable lifting and carrying, but without handles or projecting handholds (cf. Section 2.1.7).
- The bottoms of trays must not be perforated. This prevents the forming of a vacuum during automatic depalletising in the warehouse.
- Perfect stackability must be ensured, therefore bulging of the master cartons caused by overpacking is not permitted.

2.1.2 Gluing and perforation

- A sufficient bonding of the secondary packaging is necessary so that it withstands the tensile and compressive forces that occur during conveyor transport, as well as the automated depalletising and picking processes.
- However, the bond should not be too strong in order to ensure the smooth disposal of the secondary packaging in the store (see Section 2.2.5).
- The upper and lower sections of a secondary packaging are to be joined by adhesive dots, where the weight and the breakage sensitivity require it. Lifting and pulling during picking must be ensured without the two sections separating from each other. No adhesive tape or similar articles may be used.
- The adhesive must not continue to stick after opening the secondary packaging.
- Tear tapes and perforations are only permitted in coordination with the responsible contact person of REWE Group. In this case, a perforation must be designed so that it does not accidentally open during automatic depalletising and picking, and does not fray in the store after the carton has been opened.
- If the secondary packaging is intended for in-store presentation, it must be completely free of adhesive materials (e.g. adhesive tapes). Exemption: sticker on the bottom of the carton which cannot be seen when display on the shelf.



Fig. 8 - The secondary packaging must be free of adhesive materials

2.1.3 Plastic film

- The necessity of using plastic film as secondary packaging must be checked with the respective REWE Group contact person.
- As the REWE Group intends to eliminate or reduce to a minimum the use of plastic film, plastic films or polybags should only be used if they are absolutely necessary. This must be agreed with the responsible REWE Group contact person.

2.1.4 Weight

- The maximum weight of the secondary packaging is subject to the weight limits specified by the respective employer's liability insurance association.
- In general, the weight of a single secondary packaging unit should not exceed 15 kg.
- However, if the product-specific properties (e.g. the weight of the primary packaging) exceed the maximum recommended weight, appropriate warnings should be provided on the secondary packaging (for an example see Fig. 9).
- If the recommended maximum weight is exceeded, the requirements of logistics must be set above the requirements of the store in the event of conflicting requirements from the store and logistics with regard to secondary packaging.

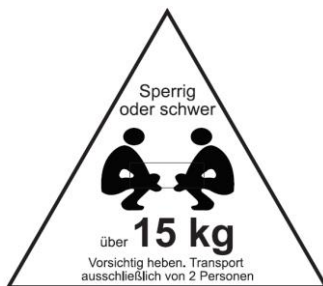

Fig. 9: Example of labelling for heavy secondary packaging over 15 kg

2.1.5 Dimensions

- The dimensions of secondary packaging must always be aligned with ISO module dimensions, and have one of the following basic (depth x width) ISO modular dimensions.
 - 1200 x 800 mm
 - 800 x 600 mm
 - 600 x 400 mm
 - 600 x 200 mm
 - 600 x 100 mm
 - 400 x 400 mm
 - 400 x 300 mm
 - 400 x 200 mm
 - 400 x 150 mm
 - 300 x 200 mm
 - 300 x 100 mm
 - 200 x 200 mm
 - 200 x 150 mm
- At the same time, the dimensions of the secondary packaging should be chosen in such a way that there is no instability (e.g. due to goods being packaged too loosely inside).
- Both the quality of the layer form and the efficient use of transport capacity depend on the dimensions of the secondary packaging (cf. Chapter 5.1).
- The depth (length) / width / height ratio should be sensibly chosen (largest area = lying area) so that the secondary packaging can be optimally aligned with the conveyor machinery.
- The height / width ratio should not exceed 1.8.
- The height of the secondary packaging must not exceed 900 mm. In exceptional cases, e.g. with a display, the maximum height must not exceed 1800 mm.

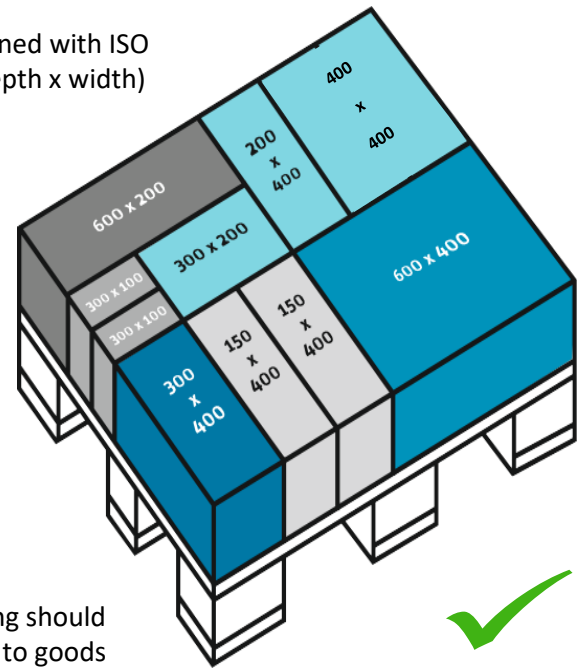

Fig. 10: Modular dimensions

2.1.6 Display and tray cartons on the lattice table

- Display and tray cartons for use on lattice tables in the stores are to be set up in such a way that the carton can be positioned to promote sales.



The table dimensions in the **Penny** distribution channel are as follows:

- Mesh table: 116 cm wide, approx. 76 cm deep
- Mesh cage: 116 cm, approx. 37 cm deep



The table dimensions in the sales channel **REWE** and **toom Baumarkt** must be agreed with the respective REWE Group contact person.

2.1.7 Bottom, cover, handles and handholds

- The bottom must have sufficient rigidity, it must not sag and must be evenly flat throughout.
- A cover for the secondary packaging must be used if the contents of an opened packaging has insufficient inherent stability to allow other packaging to be stacked on top of it.
- The cover must be sufficiently fixed to allow for the lifting of the entire secondary packaging (e.g. in automated depalletising). Fixing should only be done by way of sticking or gluing, not with securing or adhesive tapes. Likewise, the packaging should not be wrapped in film or shrink-wrap.

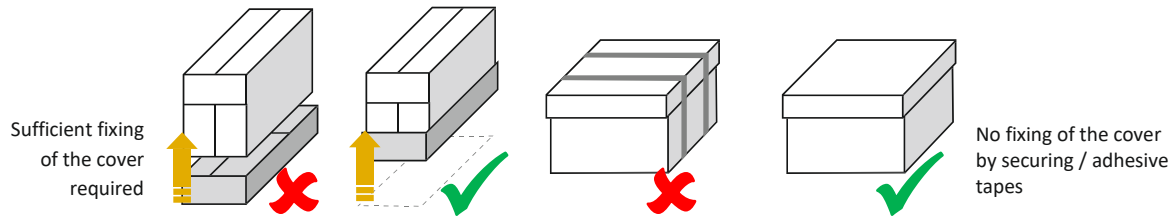

Fig. 11: Carton cover

- Protruding handles or handholds must be avoided, as they are disruptive and cannot be handled by automated goods processing systems. If a handhold is necessary, it should be integrated in the packaging or fit tightly against the packaging when not in use.

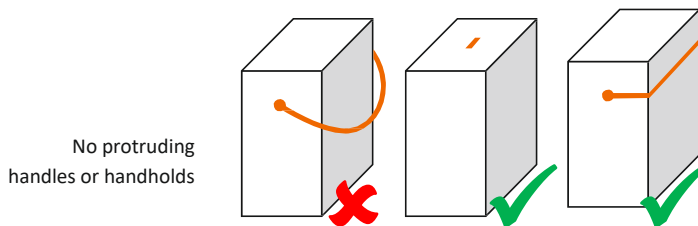

Fig. 12: Handles and handholds

2.2 Functional requirements

2.2.1 Easy identification

In order to meet the requirements for the identification of goods, any secondary packaging must, among other things, fulfil the following criteria:

- Visibility of the product through the packaging or a depiction of the product on the packaging is advantageous.
- At least two declaration boxes must be included on 2 adjacent sides of the secondary packaging (exception: display sides).
- The declaration boxes must be at least 8 mm and not more than 100 mm from the edges of the container or packaging.

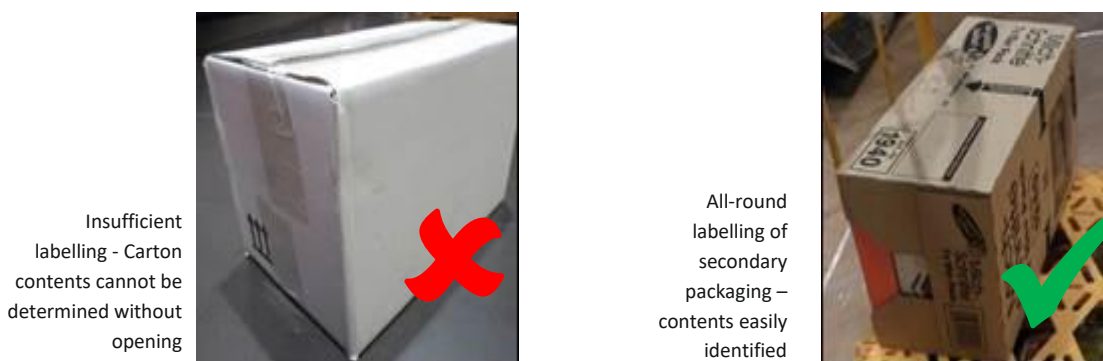

Fig. 13: Easy identification

- The following elements must be placed in the declaration box:
 - a) Product name (including additives and properties, e.g. “Graded”)
 - b) Full name of the product (formerly referred to as the sales name)
 - c) NAN + supplier’s article number
 - d) Quantity (pack unit x pack size)

- e) Storage instruction (adopt from the primary packaging, if storage information is shown here)
- f) MHD note, if required
- g) Batch number
- h) Carton GTIN: In principle, the 13-digit number applies to secondary packaging; it must be printed on the secondary box as a barcode in EAN 13 format with the following specifications:
 - Minimum size SC3-SC5
 - Minimum quality 3B
 - Free space left and right with at least 3 mm on each side (quiet zones)
 - The print quality must conform to ISO 15416

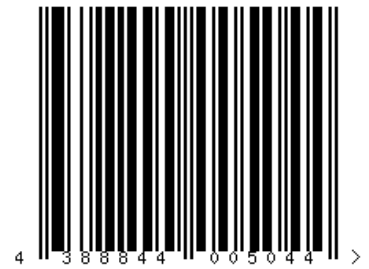

Fig. 14: Example of a barcode

- The responsibility for the readability of the texts remains with the supplier. To ensure readability, the information should be easy to read and be printed in the largest possible font size (for the information relevant to collection a) -h), i.e. at least 18pt or otherwise at least 12pt) in a standard sans-serif typeface (e.g. Helvetica or Ariel).
- Dangerous goods labels are to be attached in the middle of the back.
- Specific country specifications for exports must be taken into consideration by the supplier when marking secondary packaging.

Side 1: Main Mark of carton (mandatory)	Side 1	Side 2: Main Mark of carton (mandatory)	Side 2	Side Mark (optional information)	Side 3	Side Mark (optional information)	Side 4
Product Name/ Full Name of Product: 2 LED 'Wandleuchte' 'Danzig' warmweiß 605 lm 9170468 NAN: 9170468 Supplier Article No.: 119RX5055 Batch No.: 1042183502019 Quantity: 2 pcs. x 5 cs. (VE) Carton GTIN: 4388833916924		Product Name/ Full Name of Product: 2 LED 'Wandleuchten' 'Danzig' warmweiß 605 lm 9170468 NAN: 9170468 Supplier Article No.: 119RX5055 Batch No.: 1042183502019 Quantity: 2 pcs. x 5 cs. (VE) Carton GTIN: 4388833916924					

Fig. 15: Example for the Marking of the Secondary Packaging

Note:

- Shown information on these 2 adjacent sides of the carton are mandatory. The information can be found in the Blanket Purchase Order.
- Handling Instruction Symbols must be defined according to the content and the article characteristics:
 - use fragile symbol only if content is breakable (see chapter 4.5)
 - recycling symbol must be used in accordance with the material of the carton (see chapter 1.2.2)
- Additional information on side 3 and 4 is optional and can be defined by REWE Far East Merchandiser or supplier himself

2.2.2 Easy opening

- Essentially, the secondary packaging must be easy to open at the POS with sufficient stability (see Section 2.1.1).
- However, secondary packaging must not open during automatic picking.
- The following requirements must also be observed:
 - Quick and reliable opening of the secondary packaging without the use of force, with as little as a one-handed operation (e.g. with slip-on lid with fixed adhesive dots).
 - It should be possible to open the packaging without the use of tools, otherwise there is a risk of damaging the products.
 - Visible and easy to understand instructions for opening the outer packaging e.g. through the use of pictograms.

- The use of shrink film is only permitted in consultation with the responsible REWE Group contact person. If the use of shrink film is necessary, it should have a predetermined breaking point or perforations.
- Secondary packaging intended for presentation on the store shelves should be usable as a tray after opening.

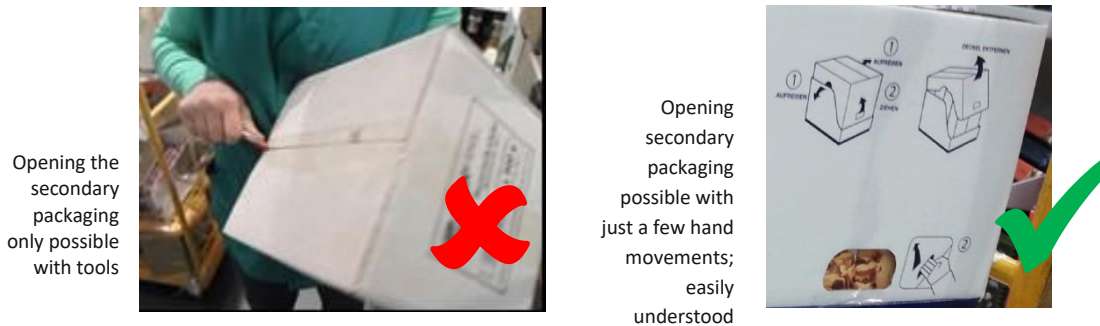

Fig. 16: Easy opening of secondary packaging

- For secondary packaging, which is only intended for transport and not for the presentation of goods in the store, the design FEFCO 0204 is permitted in accordance with the internationally valid FEFCO catalog. The seamlessly adjacent inner flaps protect the product or the primary packaging from cuts when opening (e.g. with a cutter knife). This applies to both the inner flaps on the bottom of the box and the inner flaps at the top of the box. It is also allowed to use inlays which cover the entire surface to protect the product.

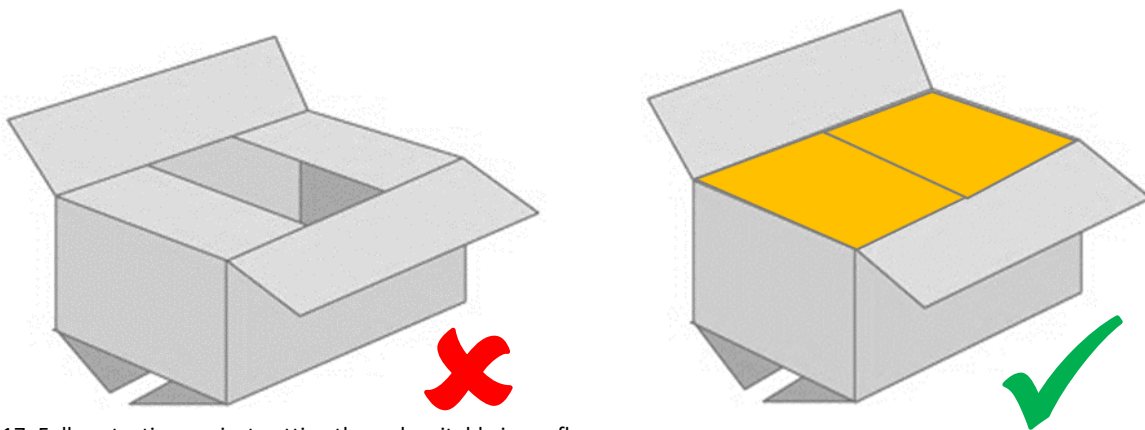

Fig.17: Full protection against cutting through suitable inner flaps

2.2.3 Straightforward placement

In order to quickly fill the shelf with a few hand movements, the following points must be observed regarding secondary packaging intended for presentation on the store shelves.

- The front sides of the products must be visible in the secondary packaging.
- For trays, the height of the sidewall must be at least 30% of the product height, and usually not less than 40mm.
- The front bar must be sufficiently low.
- If necessary, the edges should be reinforced to ensure stability.
- The secondary packaging should guarantee the stable positioning of the products on the base.



Fig. 18: Stability of secondary packaging

2.2.4 Easy shopping

The following requirements must be met:

- Good visibility of product, brand and variant
- Easy removal and return of products from the tray and back
- When using raised bars, easy removal of the product must be possible without causing damage.
- Any information of minor importance for customers can be printed on the back.

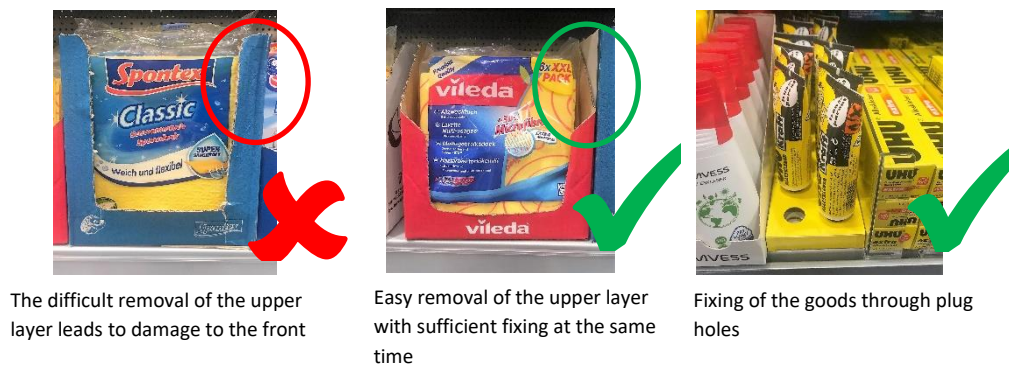
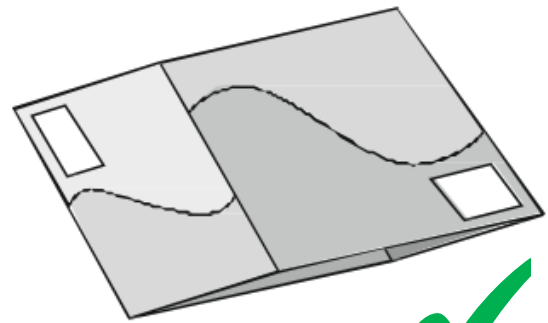

Fig. 19: Fixing of the goods and product removal

2.2.5 Easy disposal

- Easy disposal is important to keep the aisles in the store free and open.
- The packaging must be easy to fold and dispose of without tools.
- Single-material packaging is preferable for secondary packaging.
- If several packaging materials are necessary, they must be easy to separate.
- Adhesive tape, staples and the like must not be used. An exemption for the usage of staples are heavy items where necessary.
- Recyclable packaging materials should be used wherever possible.

Difficult disposal
due to different
packaging
materials



Easy to fold secondary
packaging

Fig. 20: Simple disposal

2.3 Secondary packaging as transport unit

The secondary packaging can also be the transport unit. In this case, the requirements for transport units must be observed (see Section 4).

3 Requirements for tertiary packaging

The REWE Group distinguishes between master cartons and pallets as tertiary packaging. Their requirements are set out in the following sections.

3.1 Requirements for master cartons

3.1.1 Definition and purpose

Note: In addition, the requirements for the transport unit automatically apply to the master carton. See also Section 4.

- If the use of master cartons is being considered, their necessity and cost effectiveness must be agreed with the REWE Group contact person.
- Master cartons serve to minimise handling costs during container unloading. Therefore, a master carton can only be used if at least 5 or more units of secondary packaging can be bundled in one master carton.
- Where a master carton provides protection to the secondary packaging from external influences such as heat etc. (e.g. for transport in containers through different climate zones), fewer than 5 secondary cartons may, in individual cases, be bundled in one master carton. However, this is only permitted in consultation with the responsible REWE Group contact person.
- The weight of a single transport carton must not exceed 15 kg.

3.1.2 Types

- According to the internationally valid FEFCO catalogue, two types are permitted
 - FEFCO 0201
 - FEFCO 0204
- Perfect stackability must be ensured, therefore bulging of the master cartons caused by overpacking is not permitted.

3.1.3 Dimensions

- For transport cartons, the dimensions for secondary packaging as described in Section 2.1.5 shall apply.
- The plan dimensions of 800 mm x 1200 mm and the 900 mm height dimension must not be exceeded.
- To optimise the use of space in a container or on a pallet, the master cartons should be based on the ISO basic module size 400 mm x 600 mm. Smaller or larger cartons should correspond to a submodule or multiple of this basic module dimension (c.f. Section 2.1.5).

3.1.4 Labelling

The master carton should be labelled on two adjacent sides with the following information:

- a) Product name including additives and properties (e.g. "Graded")
- b) Full name of the product (formerly referred to as the sales name)
- c) Article number (NAN) and supplier's article number in accordance with purchase contract
- d) Quantity: Number of packaging units (PU) and number of items (pieces)
- e) Storage instructions (take from the primary packaging, if storage information is shown here)
- f) MHD note, if required
- g) Batch number (*Composition: NAN + KW delivery date + year delivery date*)
- h) A carton, of the level of the tertiary packaging hierarchy, must have the designation "Master Carton" clearly marked on the carton in large letters
- i) EAN 13 Barcode of the master carton GTIN, if stated in the (Blanket) Purchase Order ("BPO"): Basically, the 13-digit GTIN applied in a EAN 13 Barcode format to the master carton with the following requirements
 - Minimum size SC3-SC5

- Minimum quality 3B
- Free space left and right with at least 3 mm on each side
- The print quality must conform to ISO 15416
- The responsibility for the readability of the texts remains with the supplier. To ensure readability, the information should be easy to read and be printed in the largest possible font size (for the information relevant to collection a) -h), i.e. at least 18pt or otherwise at least 12pt) in a standard sans-serif typeface (e.g. Helvetica or Ariel).
- Dangerous goods labels are to be attached in the middle of the back.
- Specific country specifications for exports must be taken into consideration by the supplier when marking the transport unit.



For **textile articles**, the master carton label must also contain the **Country of Origin** information



Side 1: Main Mark of carton (mandatory)	Side 1	Side 2: Main Mark of carton (mandatory)	Side 2	Side Mark (optional information)	Side 3	Side Mark (optional information)	Side 4	
	<p>MASTER CARTON</p> <p>Product Name/ Full Name of Product: LED Wandleuchte 'Danzig' warmweiß 605 lm</p> <p>NAN: 9170468</p> <p>Supplier Article No.: 119RX5055</p> <p>Batch No: 1042183502019</p> <p>Quantity: 2 pcs. x 5 cs. (VE) x 10 cs.</p> <p>Carton GTIN: 4388858914530</p>  		<p>MASTER CARTON</p> <p>Product Name/ Full Name of Product: LED Wandleuchte 'Danzig' warmweiß 605 lm</p> <p>NAN: 9170468</p> <p>Supplier Article No.: 119RX5055</p> <p>Batch No: 1042183502019</p> <p>Quantity: 2 pcs. x 5 cs. (VE) x 10 cs.</p> <p>Carton GTIN: 4388858914530</p>  		<p>Sender: Supplier ABC</p> <p>Recipient: REWE – Zentral GmbH</p> <p>BPO No.: 212063075</p> <p>Measurement: 40 x 30 x 30 cm</p> <p>Gross Weight: 15 kg</p> <p>Net Weight: 14.5 kg</p> <p>Carton No.: 1/1.000</p>		<p>Sender: Supplier ABC</p> <p>Recipient: REWE – Zentral GmbH</p> <p>BPO No.: 212063075</p> <p>Measurement: 40 x 30 x 30 cm</p> <p>Gross Weight: 15 kg</p> <p>Net Weight: 14.5 kg</p> <p>Carton No.: 1/1.000</p>	

Fig. 21: Example of the Marking of Tertiary Packaging

Anmerkungen:

- The information displayed on these two adjacent sides of the box is mandatory. The information can be found in the BPO.
- Action instruction symbols must be defined according to the content and the item properties:
 - Only use the fragility symbol if the content is fragile (see chapter 4.5).
 - The recycling symbol must be used according to the material of the box (see chapter 1.2.2)
 - Only use the heavy 15 kg symbol if the carton weight is 15 kg or more.

3.1.5 Easy disposal

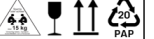
- Easy disposal is important to keep the aisles in the warehouse free and open.
- The packaging must be easy to fold and dispose of without tools.
- Single-material packaging is preferable for master cartons.
- If several packaging materials are necessary, they must be easy to separate.
- Adhesive tape, staples and the like must not be used. An exemption for the usage of staples are heavy items where necessary.
- Recyclable packaging materials should be used wherever possible.

3.2 Requirements for Euro pallets

3.2.1 General requirements

- In principle, only Euro pallets of the quality level Class C (exchangeable) or better are to be used. However, for delivery to semi- or fully automated warehouses, only Class B Euro pallets conforming to GS1 standard and quality standard UIC 435-2 (or better) are to be used.
- The dimensions must be 1200 x 800 x 144 mm (L x W x H).
- At least one label must be readable.

- The pallet is machine-compatible and suitable for use with conveyor belts (chain and roller conveyors).
- Good condition of the pallet is mandatory: a detailed contour and stability check should be made upon collection of all pallets (see Fig. 22) with a focus on runners and fork clearance. The pallet must not have any twisted blocks or other damage (such as incomplete runners, protruding splinters).
- The pallet must not have any residues of cardboard, plastic film, tapes or labels stuck to it.
- The maximum permitted residual moisture of the pallet is 22%. This results in a maximum permitted dead weight of 22 kg.
- Euro pallets must not be used for imports from Asia and outside the EU.



In special cases and subject to consultation with the REWE Group contact person, so-called "Düsseldorfer pallets" or half pallets with the dimensions 800 x 600 mm can also be used for the sales channel **Penny** and **toom Baumarkt**.

The following images show incorrect cases that must be checked upon the receipt of goods:

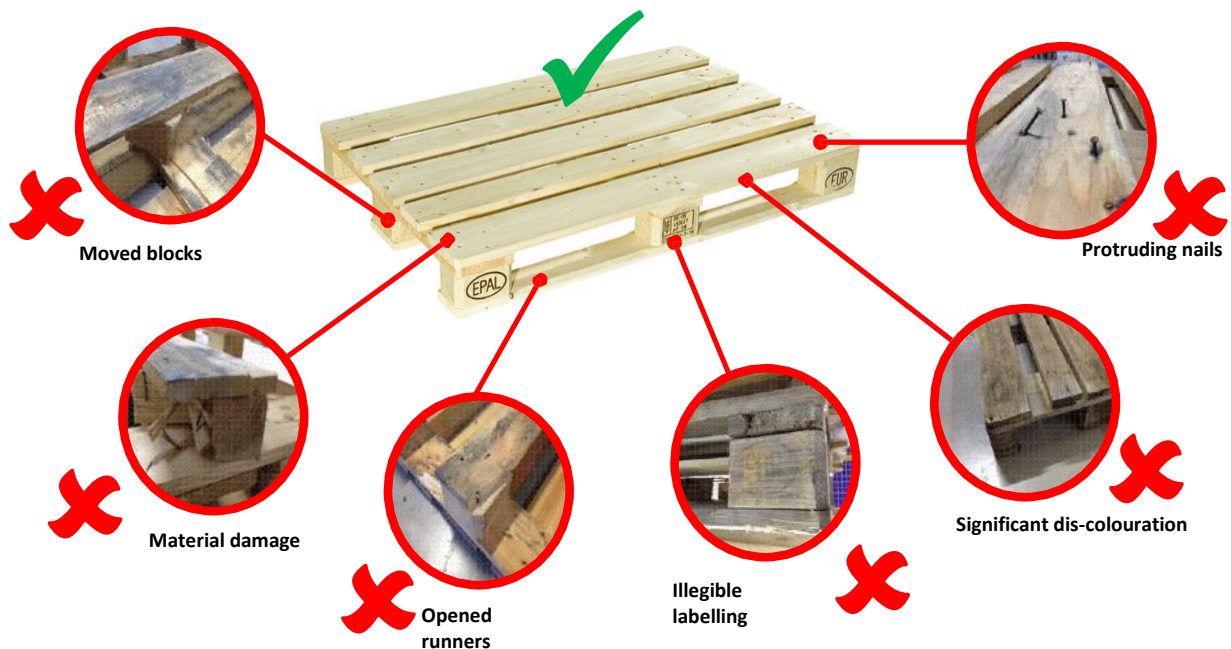

Fig. 22: Examples of Euro pallet faults

3.2.2 Optimal pallet utilisation

- The area of the pallet must be fully utilised.
- The edge protection for load securing must be taken into account.

- Pallet overhangs and underhangs must be prevented. They are generally not permitted, especially when the pallet leaves the warehouse of origin. Tolerances on arrival of the goods are a total of 2 cm in depth (length) or width (N.B. allow for edge protection and film).

! Should pallet overhangs or underhangs occur, the goods flow controller for the **Penny** sales channel must be informed, in order to coordinate the goods receipt.

! **toom Baumarkt** reserves the right to refuse acceptance in the event of pallet overhangs.

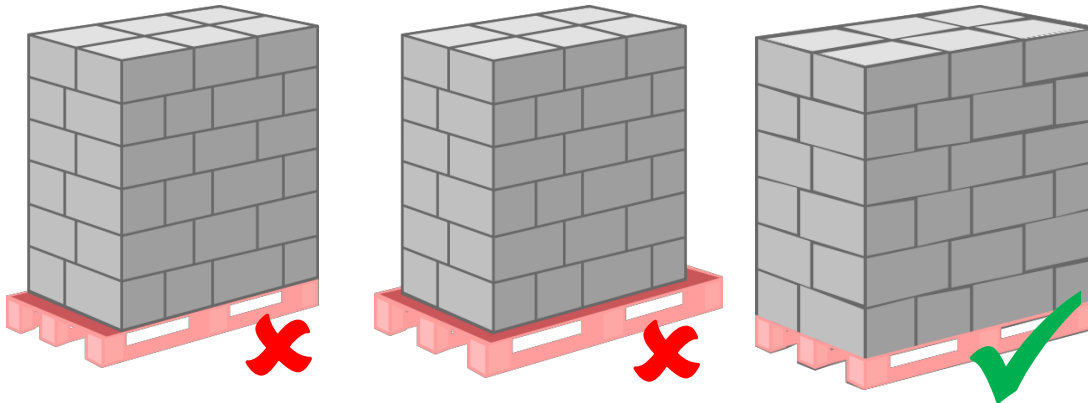

Fig. 23: Optimal pallet utilisation

3.2.3 Height and weight of the loading unit

- The maximum height (including pallet wood) is 105cm (CCG1) or 195cm (CCG2).
- Exceptions must be agreed with the respective contact person of REWE Group in consultation with Logistics.

! At the warehouse locations (warehouses 004 and 110) of **toom Baumarkt GmbH** in Dietzenbach the maximum packing height for CCG1 pallets is 1100 mm (including the pallet).

! For defined warehousing locations, in particular for **toom Baumarkt GmbH** and **REWE-Beteiligungs-Holding International GmbH (Penny International)**, the delivery of CCG 2 pallets with a maximum height of 1800 mm including pallet wood is mandatory.

- If necessary, ½ or ¼ pallets can be delivered on a Euro pallet.

! This is expressly prohibited for **toom Baumarkt** Non Food items.

- ½ and ¼-pallet displays must not be top-heavy. The tipping point should be in the lower half.
- The maximum permitted load capacity of the pallet is 1,000 kg.

! For certain warehouse locations of **REWE-Beteiligungs-Holding International GmbH**, the maximum weight per pallet is less than 1000 kg.

- Several pallets, each with a few layers, can be stacked without excess up to a total height of CCG1 or CCG2 and a total weight of 1000 kg. However, this is subject to the precondition that the goods are not impaired and the individual Euro pallets are of one sort, i.e. various items are separated from each other by a Euro pallet. In order to protect the primary and secondary packaging, it is essential to use full-coverage corrugated cardboard interlayers.

- ! Additional specifications for warehouses of **REWE-Markt GmbH** or **Penny-Markt GmbH** can be found in the REWE Group's service catalogue in the [REWE Supplier Portal](#) (under the topics "Information" > "Delivery Processes" > "Supplier Service Catalogue").

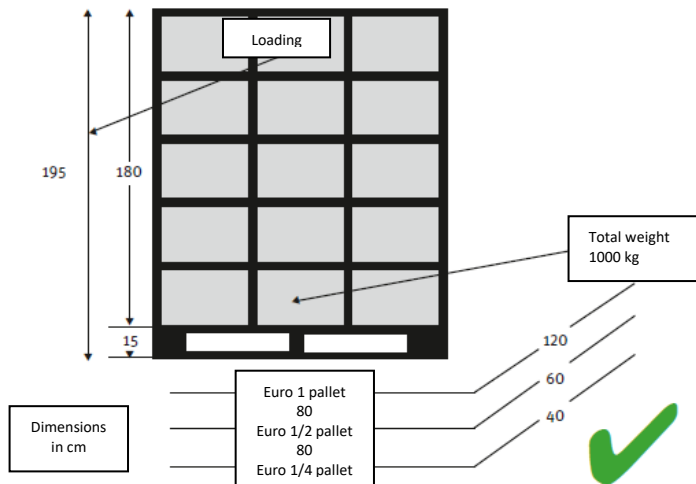

Fig. 24: Height and weight of the pallet

3.2.4 Layer form

One layer with packaging units:

- weighs a maximum of 300 kg.
- is flush with the surface, closed and has a uniform height.
- The forming of "chimneys" (voids) is fundamentally excluded (see Fig. 25)*.
- has only covers or openings that open upwards.
- The use of empty cartons for stabilisation is prohibited.
- The gluing of layers or cartons to each other, e.g. using glue dots, Scotch tape etc. is prohibited.

- ! * In exceptional cases and depending on the product properties, the forming of a "chimney" may be necessary. This can affect especially too many Baumarkt articles (with PU = 1). **In this case the respective REWE Group contact person must be informed.**

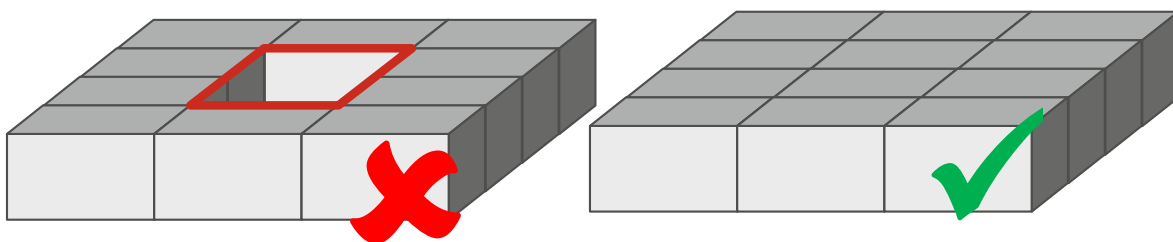

Fig. 25: Left: "chimney form" (generally not permitted), Right: suitable layer form

- In any case, the uniformity of the packing formation in the packaging units per layer and loading unit is mandatory.
- Both the packaging units per layer and the layers per pallet must each have the same height.

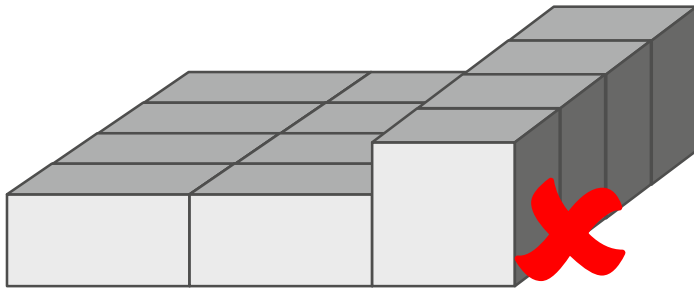

Fig. 26: Inconsistent packing formation

3.2.5 Load securing

- The load must be secured in such a way that both automatic and manual handling is possible during transport and storage.
- Load securing devices are to be used as much as necessary, and as little as possible.
- The use of securing straps and layer bonding is prohibited.

3.2.5.1 Load securing by wrapping with stretch / shrink film

- The loaded pallet is secured by stretch film or shrink wrap (not adhesive film), that is only minimal connected to the pallet wood.
- In the case of sandwich pallet, the timbers must be individually wrapped or shrink-wrapped.
- The wrap / shrink-wrap must cover the entire load.
- The film may only wrap around the carrier pallet in the area of the deckboard, in order to allow its smooth handling for industrial trucks.

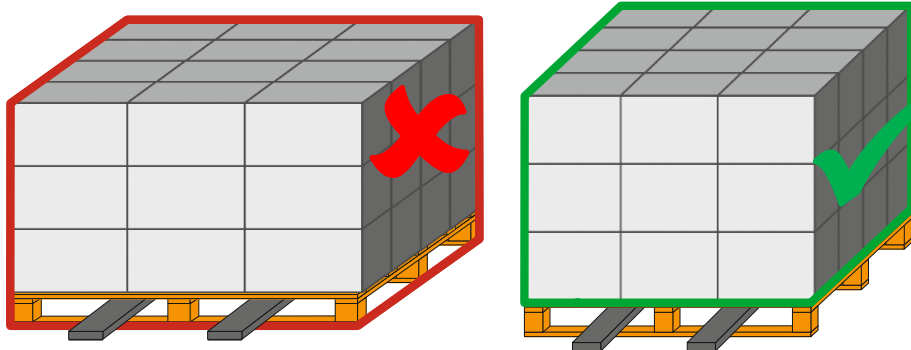

Fig. 27: Wrapping the pallet

Euro pallet with wrapping -
Handling for floor cars difficult

Wrapping covers entire load -
Pallet easily accessible

3.2.5.2 Load securing with impact protection

For use with very fragile products, and those prone to leaking /trickling out.

- A cardboard box is to be used to the quality stipulated in the requirements.
- It is essential to use impact protection around the lowest layers.
- The impact protection must not be glued to the load or connected in any other way.
- When using impact protection, there must be a perforation to allow its quick removal before depalletising can begin.
- If additional strapping is necessary for logistical reasons, its use must be agreed in advance with the REWE Group contact person. When using strapping, appropriate edge protection (see Section 3.2.5.3) must be attached. If necessary, additional corner protectors are to be used.

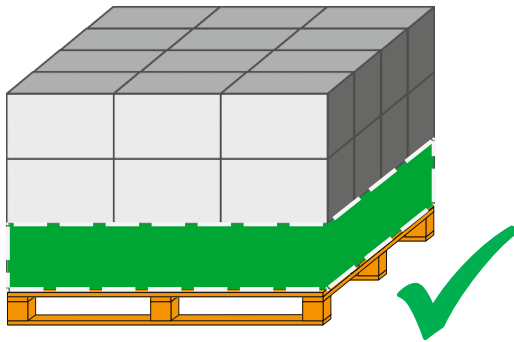

Fig. 28: Sufficient impact protection

3.2.5.3 Load securing with edge protection

- Edge protection may be used when stretch / shrink film subjects the cargo to unnecessary pressure.
- Edge protection is used to stabilise layers that are prone to slipping, and to prevent damage to sensitive products.
- The edge protection cardboard must be stable.
- It surrounds the vertical edges of the goods and may only be on the sides.
- Do not attach edge protection between the pallet and the load, i.e. it must be possible to remove it quickly!

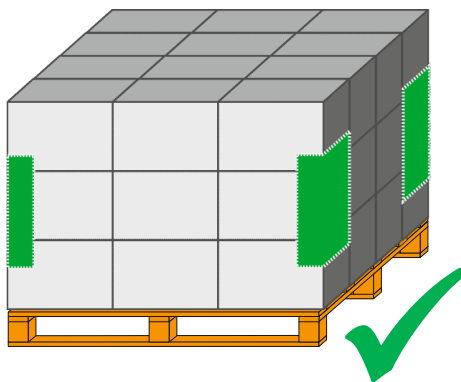

Fig. 29: Sufficient edge protection

3.2.5.4 Load securing through intermediate layers and covers

Intermediate layers / covers are only to be used in extreme cases:

- Generally speaking, intermediate layers should be avoided, because, among other things, they can make automatic depalletising difficult, or even impossible.
- The use of intermediate layers is only permitted in exceptional cases, if it is not otherwise possible to ensure the stability of the load.
- Covers are only permitted where the load has to be protected against quality-reducing environmental influences.

If an intermediate layer has to be used:

- It must be agreed with the REWE Group contact person, so that the warehouse sites can be informed about it.
- Each layer must be given an intermediate layer.
- Only one intermediate layer may be used per layer.
- The intermediate layer must consist of one piece.
- The area of the intermediate layer should exactly match the area of the layer.
- The maximum dimensions of 1200 x 800 mm must be observed.

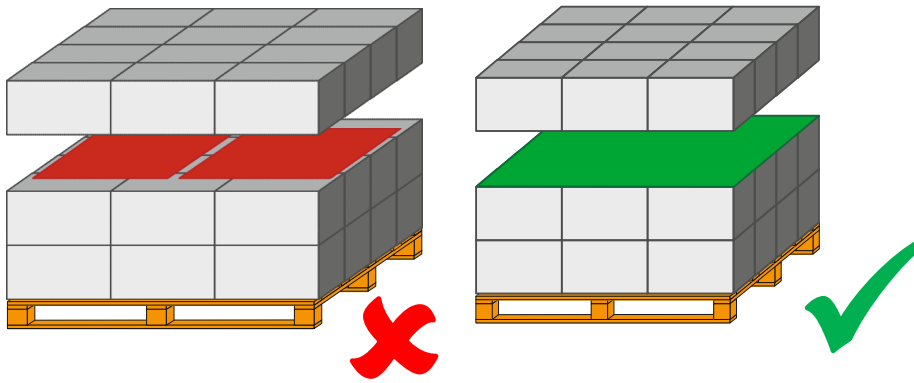

Fig. 30: Intermediate layers

For defined storage locations with semi- or fully automated warehouses of REWE Group, the following applies to intermediate layers:

- Only cardboard may be used.
- Full cardboard or corrugated cardboard may be used. The thickness of a sheet should be ≥ 1 mm for solid board, ≥ 2 mm for corrugated board.
- Thin paper or plastics are not permitted.
- The intermediate layer must not be deformed by the suction force created by the depalletiser (see Fig. 31).
- The surface must not be too smooth or dull.
- The intermediate layer must not involve the use of adhesive.
- The intermediate layer must not have any holes or perforations, as this would prevent the generation of a vacuum during the depalletising process.



Fig. 31: Maximum permissible cardboard deformation due to suction force of the depalletiser

3.2.6 Composite stacking

- In principle, composite stacking is always preferable to the use of intermediate layers or the application of adhesive bonding methods.
- The packing variants / composite stacking offers high stability even during in-house transport, without the use of additional load securing devices.
- The offset stacking of transport cartons (see Fig. 32) creates a level of stability as can be seen in wall construction.

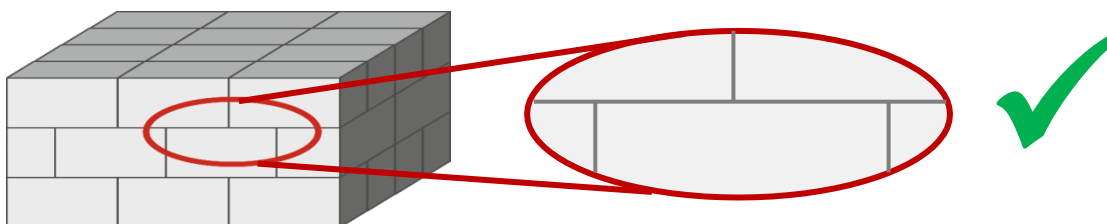

Fig. 32: High stability due to composite stacking

3.2.7 Identification / labelling of the pallet

- Every pallet must be identified by two GS1 transport labels stuck to the outside of the film.



Alternative for non-EU suppliers: the attachment of a sticky label containing the same information as in Chapter 3.1.4.

- The GS1 transport label (formerly EAN 128 or SSCC transport label) is divided into three segments:
 - The header section of the transport label clearly states the addresses of the goods shipper and recipient, and can include the logo of the shipper.
 - The middle section should contain - also clearly written - any accompanying information intended for staff at the loading bay or in the warehouse.
 - Bottom section: the display of this information (data elements) in the form of a bar code in GS1 / EAN 128 format, enables automatic scanner detection and thus the automatic reading of the information.
- Further information regarding the transport label can be found in the [REWE Supplier Portal](#) in the brief overview "Fundamentals of Labelling and EDI" (under the topic "Information" > "Supply Processes").

The following illustration shows an example of a GS1 / EAN 128 transport label in original size.

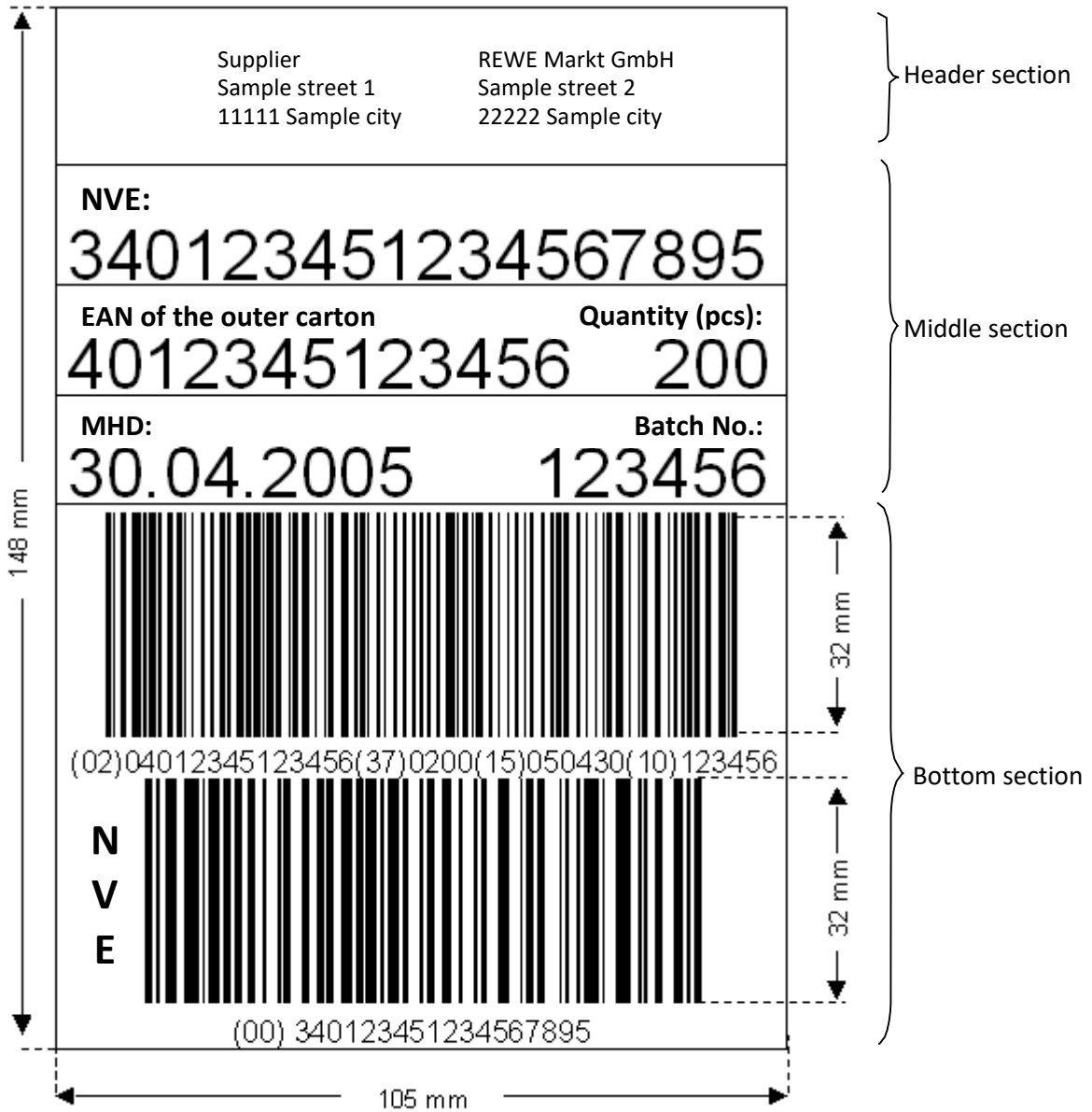

Fig. 33: Example of a GS1 / EAN 128 transport label (original size) (Source: PROZEUS brochure for staff: EAN 128 transport label, Centrale für Coorganisation GmbH (CCG), Cologne)

3.2.8 Label attachment and positioning

3.2.8.1 Specifications for the positioning of the label on the transport unit

- The label should be clearly visible and legible on at least one of the front sides and the right-hand long side.
- The bottom edge of the label barcode must be a minimum of 400 mm above floor level and a maximum of 800 mm above floor level.
- The distance from the side edges should be at least 50mm.
- If the pallet is below a height of 400mm, the label should be placed as high as possible.
- Any additional labels should be placed above the existing label. For reasons of processing safety and security, never place multiple labels of the same content on the same side of the logistical unit.

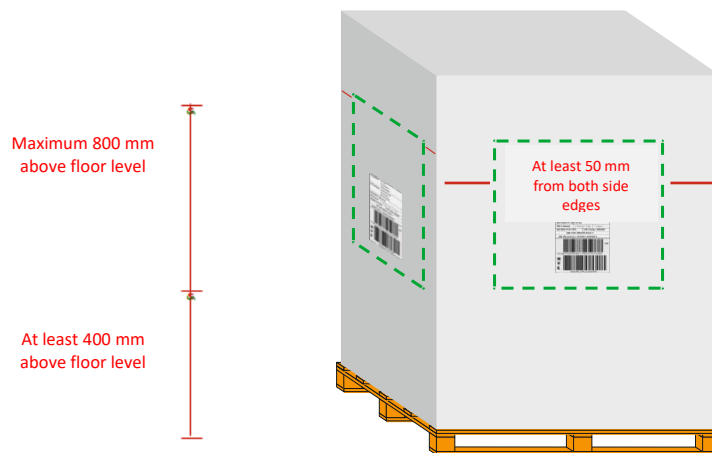

Fig. 34: Attaching the GS1 / EAN 128 transport label

3.2.8.2 Label attachment for sandwich pallets

- With sandwich pallets, different items are stacked on top of each other on a shipping unit in complete layers.
- The layers of unmixed items of are separated from each other by a Euro pallet (intermediate pallet) including an intermediate layer made of cardboard.
- In view of the fact that sandwich pallets are usually separated in the recipient warehouse, each individual pallet must have its own GS1 / EAN 128 transport label for unambiguous identification in the downstream processes.

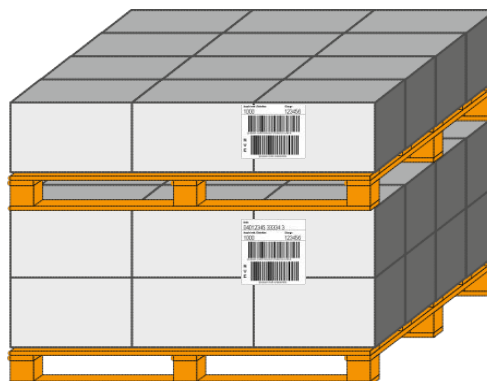

Fig. 35: Sandwich pallet

- In addition, the shipping unit must be identifiable as a unit by its wrapping and must be provided with a GS1 transport label with a so-called master NVE.

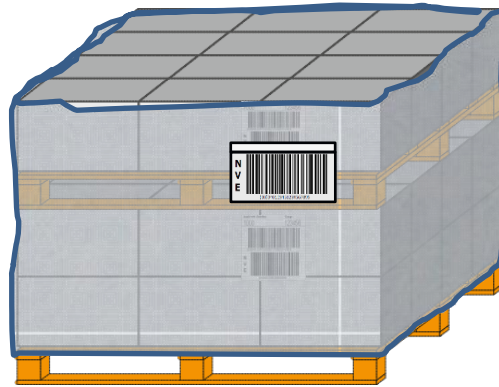

Fig.36: Wrapping of a sandwich pallet and use of labels with a master NVE

- In the case of a sandwich pallet with a master NVE, a further hierarchy level is required in the DESADV (electronic DESpatch ADVice in EANCOM® format, see also <https://www.gs1.org/>).
- The display of hierarchies 1 and 2 within the DESADV is analogous to the single variety full pallet, whereby now the 2nd hierarchy level contains the master NVE.
- In contrast to the full pallet, the GTIN of the delivered unit is now displayed in the 3rd hierarchy level of the DESADV. This 3rd level must be displayed for each delivered layer, even if the layers (intermediate pallets) contain the same items.

4 Requirements for transport units

4.1 Definition and delimitation

- In principle, every packaging level (primary, secondary, tertiary) can be used as a transport unit. For example, the primary packaging can be used for transport. That means the primary packaging would at the same time also be the transport unit. It therefore has to meet the requirements of the transport unit in addition to the requirements for the primary packaging, regardless of the packaging level, in order to ensure a smooth flow of goods.
- The requirements described in this section apply in addition to the requirements for primary, secondary and tertiary packaging. They always have to be applied to the packaging level that is being used as the transport unit.

4.2 Carton strength

- In order to ensure the strength of the transport unit during transport, the selection of the cardboard /corrugated cardboard must be geared to the maximum stacking height.
- For unpalletted transport in a container, the maximum stacking height is 2.70 m (which approximately corresponds to the internal height of a standard 40' high-cube container).
- For palletted transport in a truck, the maximum stacking height is 1.80 m (excluding pallet wood). The divergent requirements of some warehouse sites must be taken into account (cf. Section 3.2.3).
- For safety reasons, the bottom package (P1) must be able to withstand twice the total weight of the packages stacked above it.
- The supplier is responsible for the implementation of these specifications.

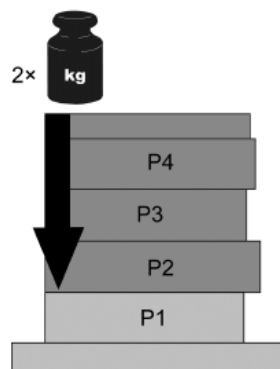

Maximum load including safety factor $2 = 2 \times$ total load on P1, which is equal to $2 \times (P2+P3+P4+...)$

Fig. 37: Maximum load

4.3 Closure

- The factory edge (adhesive flap) of the transport unit may only be glued and not stapled (no use of metal).
- A self-adhesive tape or wet-adhesive tape made of kraft paper, 50 mm wide, should be used for this purpose. A divergence of 10% in the width is permissible, provided the security of the closure of the transport unit is ensured for the whole transport process.
- In exceptional cases, the REWE Group contact person may also request a self-adhesive or wet-adhesive tape that is reinforced with at least 3 threads.
- If the use of staples and / or straps is absolutely necessary for logistical reasons, such exceptions require the prior written approval of the REWE Group contact person.

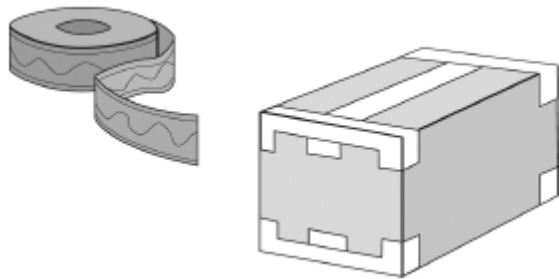

Fig. 38: Closure of the transport unit

4.4 Weight

- The weight of a single transport carton must not exceed 15 kg.
- If the 15 kg limit is exceeded, the transport unit must have appropriate warning notices, as shown in the following illustration:



Figure 39: Sample illustration for the labelling of heavy secondary packaging over 15 kg

4.5 Handling labelling

- Transport units must be marked with the legally prescribed graphic symbols (e.g. dangerous goods).
- Other graphic symbols may be used for marking transport units in the supply chain, in order to convey handling instructions. The graphic symbols should only be used when it is necessary to ensure the safe, orderly and efficient handling of the transport unit. The use of symbols conforming to ISO 780: 2015 (E) is recommended. This standard specifies the colour, size, number and position of the graphical symbols as well as the meaning of the individual symbols.

The following table shows examples of frequently used graphical symbols:







<p>Zerbrechliches Packgut Fragile, handle with care</p> 	<p>Vor Hitze (Sonneneinstrahlung) schützen Keep away from heat</p> 
<p>Oben This way up</p> 	<p>Vor Nässe schützen Keep dry</p> 
<p>Leicht entflammbar Inflammable</p> 	<p>Schwer entflammbar Low inflammability</p> 
<p>Transport von sperrigen oder schweren Waren stets von 2 Personen anzuwenden ab einem Gewicht von 15 kg für Verkaufs- und Transportkartons Bulky or heavy goods and sales packaging (15 kg and above) shall be carried by 2 persons</p> 	

Fig. 40: National and international handling markings

4.6 Bottom, corners and walls

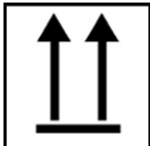
- During the entire logistical process, the bottom of the transport unit must:
 - Not tear or flap open
 - Support the contents of the packaging
 - Remain continuous (no holes), uniform, level and flat
 - Not be too smooth or high-gloss printed and preferably not be covered in film.
- The carton has right-angled external corners. Where rounded corners are necessary for secure transport (e.g. for round products), only the internal corners should be rounded.
- The walls should cover at least 1/3 of the height of the product.
- As a rule, the packaging should not be shrink-wrapped. However, if this is absolutely necessary and has been agreed with the REWE Group contact person, the shrink-wrap must be tightly fitting and taut.
- If possible, the cardboard box should not have any stacking lugs.

4.6.1 Transport units with window cut-outs

- Transport units with window cut-outs have a wall height equal to 1/3 of the height of the product.
- No cut-outs or perforations are permitted within this minimum height.
- If the window cut-out is lower, covers or inserts must be used. These must also be used if the products are non-rigid /deformable.
- If the remaining wall is of insufficient strength, it must be reinforced by carding the edges.
- Products are only then shrink-wrapped if they are inherently stable and load-bearing, otherwise a cover must be used.

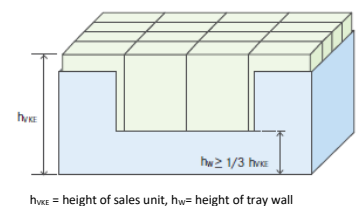

h_{VE} = height of sales unit, h_W = height of tray wall

Graphic: EHI

Fig. 41: Length ratios for transport units with window cut-outs

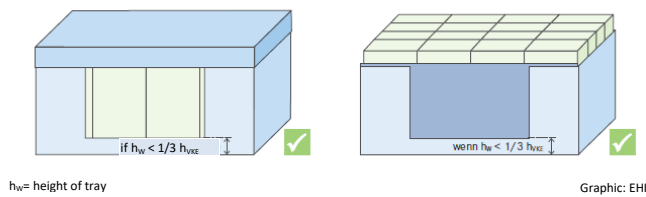

Fig. 42: Examples of possible transport units with window cut-outs

4.6.2 Two-part transport units

- A two-part transport packaging is necessary, when the products do not have sufficient inherent stability to support other goods or permit stacking.
- It has a sufficiently fixed cover (bonded or with a push-in mechanism) to prevent accidental loosening.
- In doing so, the lid does not have to support the self-weight of the packaging unit alone (as the depalletising process also involves stapling).
- Fixing with securing straps is undesirable.
- It is sensible to have a hole in the cover for opening, that does not impair the compressive strength of the packaging.
- Any finger holes should have a maximum diameter of 25 mm and be preferably spaced 80 mm apart.

4.7 Use of filler materials

- Cavities are generally not permitted.
- If it is not possible to completely fill the transport unit without cavities, due to the nature of the product or the carton of the next lowest packaging hierarchy level, the cavity must be filled with a filler material, to ensure stability in transport and prevent damage.
- Permissible padding materials include cardboard, paper and dust-free wood wool.
- Filler materials made from foodstuffs such as corn chips are not allowed.

4.8 Stability testing

- The supplier undertakes to carry out its own testing of the transport packaging. The results of the tests must be documented in writing, stating the test date and the test result. The information provided by the supplier shall be considered binding.
- REWE Group reserves the right to randomly check the supplier's information and modify the packaging until the tests have been passed. If required, REWE Group will carry out the following internationally standardised tests on the packaging units.

4.8.1 Vertical impact test (DIN EN 22248)

- The protection against breakage for a filled transport carton is tested during the vertical impact test on a hard surface (e.g. concrete, tiles).
- The order of the impact points is shown in Fig. 43 and the dropping heights used are shown in Fig. 44.

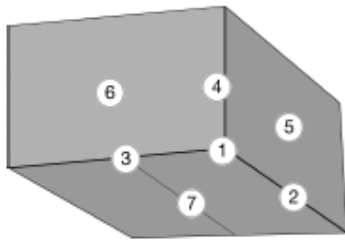

Fig. 43: Order of the impact points

Contents	Fall height at a gross weight		
	Up to 10 kg (max)	Up to 15 kg (max)	Up to 35 kg (max)
Glass / porcelain / ceramics	500 mm	400 mm	400 mm
Other articles susceptible to breakage	600 mm	500 mm	400 mm

Fig. 44: Fall heights

4.8.2 Stacking test (in accordance with DIN EN 22872)

- In this test, the stacking strength of a transport carton is tested.
- The type of corrugated cardboard to be used for the transport carton must be aligned to the maximum stacking height of the corresponding transport method (see Section 4.2).
- The value determined during this test indicates whether, at maximum stacking height, the lowest package will withstand the pressure of the overlying packages. Here, the test height is selected according to the corresponding transport method.
- The item and sales packaging must not be deformed or destroyed as a result of this test.

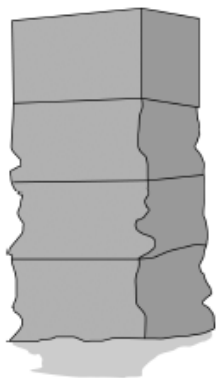

Fig. 45: Stacking test

4.8.3 Climate test

During a climate test, the climatic transport and storage conditions are simulated. Thereafter, the effects on the item and packaging are determined.

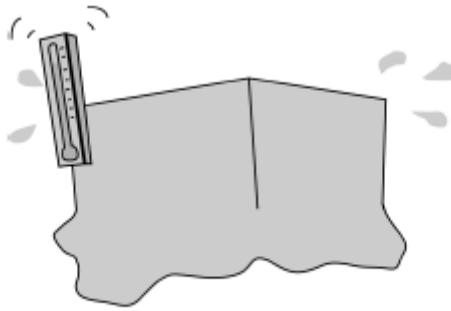

Fig. 46: Climate test

4.8.4 Vibration test (DIN EN 22247)

The durability of the item and the sales packaging is tested by simulating the transport loading during a 60-minute test on a vibrating plate.

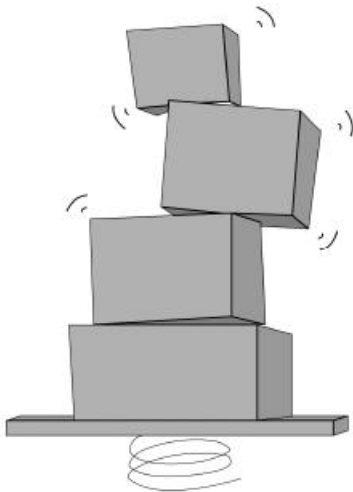

Fig. 47: Vibration test

5 Import-specific requirements

The requirements in this section apply to intercontinental shipments to Germany from countries outside Europe.

5.1 Optimisation of the packaging dimensions of a transport unit

- By optimising the dimensions of transport units for their own-label products, the REWE Group ensures the maximum utilisation of containers and pallets. This should minimise the number of containers and trucks necessary for transport and reduce the number of pallets that have to be stored. This will have a positive effect on transport and storage costs.
- Optimised transport units also usually reduce the demand for raw materials, which can reduce the costs of cardboard cartons.
- REWE Group reserves the right to determine the specification of primary, secondary or master cartons for suppliers.

5.2 Loading and load securing

- The REWE Group reserves the right to determine the size and number of containers for a shipment, and to specify a loading plan, to which the supplier must always adhere, unless it can prove that it is not feasible. The REWE Group can carry out checks at any time before or after loading.
- The supplier is responsible for the securing of the load in the container and must ensure that the transport units are adequately protected against slippage, tilt, torsion (means a lack of firmness, "instability", of the load piece) and breakage and thus also from falling out when the container is opened e.g., using securing straps, nets, or airbags. When planning load securing, measures must be taken to counteract these forces e.g., lashing (it is advisable to set lashings as high as possible), non-slip mats, fill gaps with airbags, strengthen the goods by bracing the load or by protecting it with a stable frame. In the case of goods sensitive to moisture, the cargo must be protected during container transport against moisture from condensation.
- To mitigate risks and protect the cargoes, supplier needs to ensure that the empty containers are in good condition before loading them. Suppliers have the right to reject for containers which are in unsatisfactory condition. Supplier must examine the exterior and interior of the containers for any malfunctions or damages such as holes, cracks, water stains, etc. Mark down the findings, take photos of the containers and request for a replacement if the container is not in satisfactory condition.

5.3 Use of wood packaging material¹

- Under the terms of the International Plant Protection Convention (IPPC), packaging timber must be treated prior to shipping in accordance with ISPM 15 ("Regulation of wood packaging material in international trade") to prevent the spread of harmful organisms such as fungi or insects to other areas of the world ([ISPM No. 15 - in English](#))
- This applies to packaging material made of solid wood for the transport, protection and storage of goods, including pallets, boxes, crates, drums, barrels, pallet top frame and dunnage, such as individual pieces of wood and wedges for securing goods in containers.
- Wood with a thickness of less than 6mm and wood-based materials (chipboard, blockboard, fibreboard, plywood, etc.) are **not** subject to the requirements of ISPM No. 15.
- If an item has to be heat treated or fumigated under existing IPPC regulations, the supplier shall be responsible for applying fumigation with ISPM15 procedures, officially marked with the ISPM15 stamp consisting of 3 codes (country, producer and measure applied) and the IPPC logo and must take all necessary steps to ensure the timely loading of the fumigated container. Fumigated containers are to be labelled with warnings in accordance with international transport regulations (see also the Technical Rules for Hazardous Substances – "Fumigations" (TRGS 512)). This is the responsibility of the freight forwarder.
- After fumigation, the fumigation certificate (in English), along with other shipping documents specified in the framework order, must be forwarded by the supplier to the responsible REWE Group contact person by email no later than three days after its issue.

5.4 Packaging wood from China¹

- Pursuant to the [Implementing Decision 2013/92/EU](#) (ABl. L47 20.02.2013, S.74; amended with the Implementing Decision (EU) 2017/728 dated 20.04.2017 (OJEU L107, p.33)), from 1 April 2013, increased phytosanitary checks of packaging timber used in the import of specified goods from China are required throughout the EU (see Annex 2).

¹Source: Julius Kühn-Institut, Bundesforschungsinstitut für Kulturpflanzen (Information on import and export> Wood packaging material > Import from non-EU Countries) at: <http://pflanzengesundheit.julius-kuehn.de/index.php?menuid=44> [Version 06.03.2018]

- Importers of specified goods are, in any case, obligated to register the packaging wood in use for the consignments with the competent Plant Protection Service at the point of entry via PGZ-Online (<http://pgz-online.de/>).
- Before the transfer of the specified goods in one of the following customs procedures, approval by the Plant Protection Service is required:
 - Customs clearance
 - Inbound processing
 - Conversion process
 - Temporary use
 - Outbound processing
- Plant Protection Services may omit the use of phytosanitary controls. In this case, the approval of the Plant Protection Service is still required.
- Suppliers of the specified goods must report this to the responsible REWE Group contact person if they intend to use wood packaging material (see Section 5.3), provided REWE Group is the importer of the goods.

**Annex 1: Barcode specifications per packaging type
(Illustrative presentation)**

Note: Optimal solutions for barcodes always include the minimum possible solution!

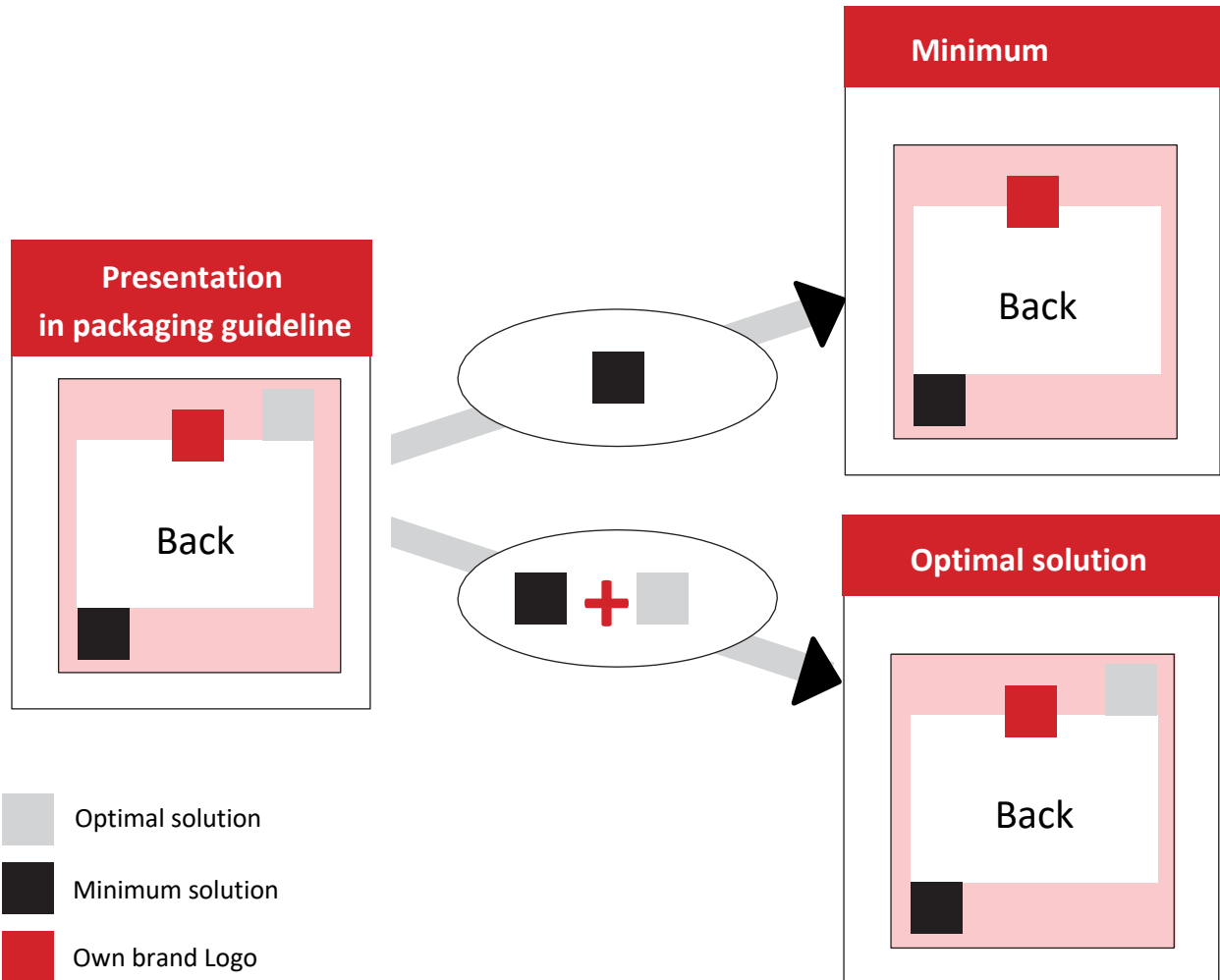
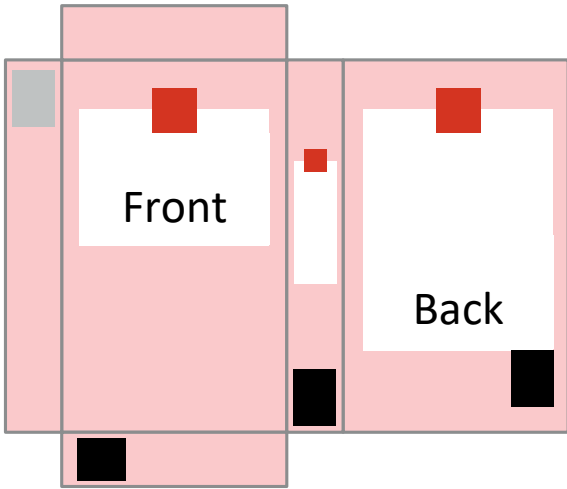

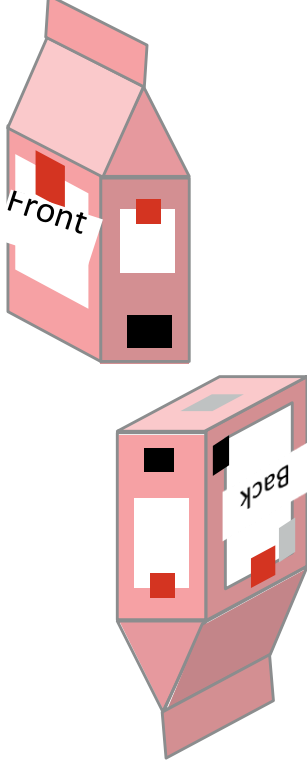
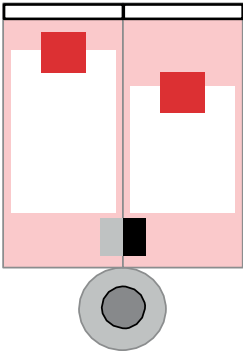
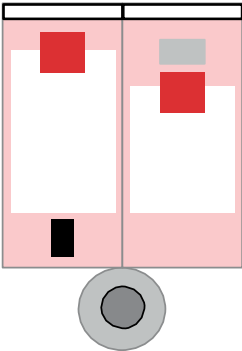

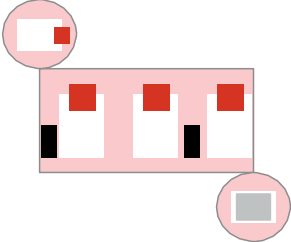
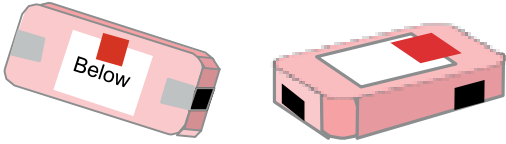

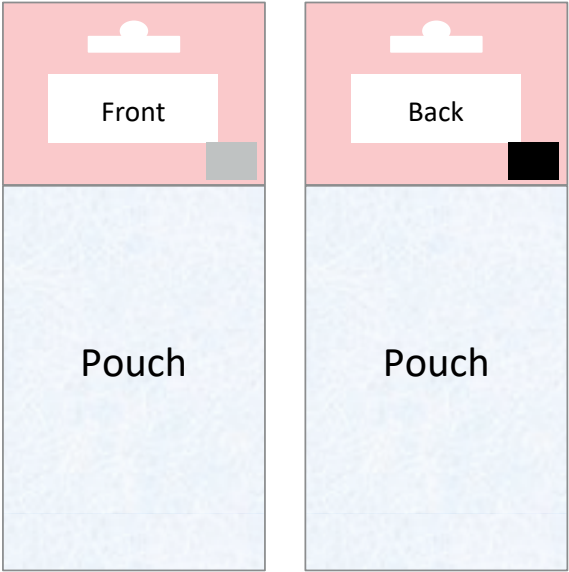
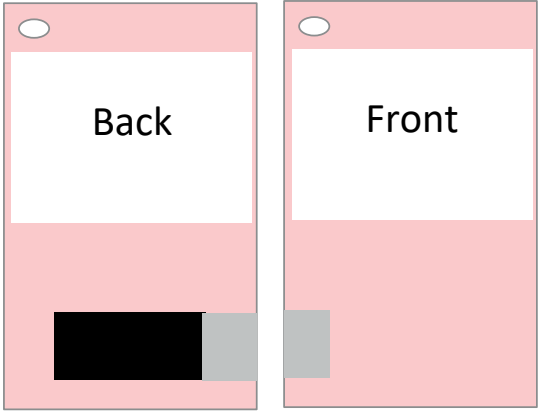
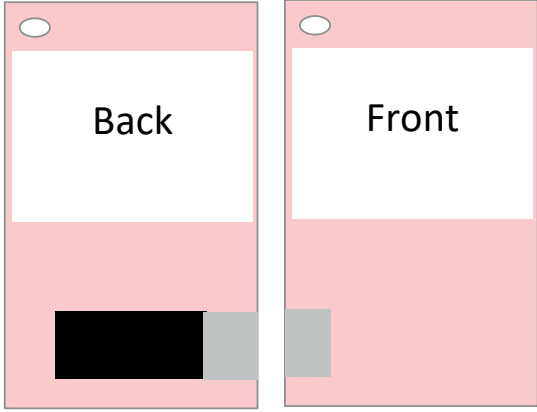
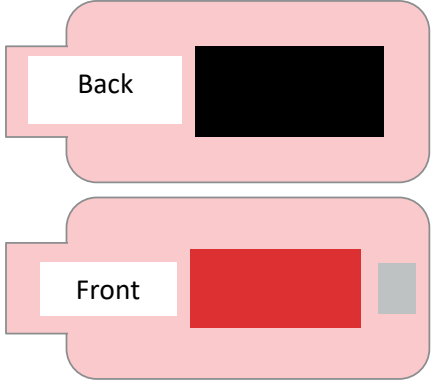

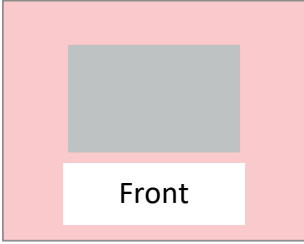

Fig. 48: Optimal vs. minimum solution for barcodes

Folding cartons / rectangular packaging	Pouches / bags
 <p data-bbox="199 920 491 1043"> Optimal solution Minimum solution </p>	<div style="display: flex; justify-content: space-around;"> <div data-bbox="858 360 1050 1003"> <p data-bbox="858 360 948 394">a) Bags</p>  <p data-bbox="847 1066 1198 1256"> Optimal solution Minimal solution X Positioning not optimal </p> </div> <div data-bbox="1123 360 1430 1196"> <p data-bbox="1161 360 1417 394">b) Stand-up pouches</p>  </div> </div>
<ul style="list-style-type: none"> ▪ At least three barcodes have to be placed. ▪ If it is not possible to put the barcode on the sides, either for optical reasons or lack of space, extend the barcode on the back or bottom as far as possible. 	<p data-bbox="858 1290 963 1323">a) Bags:</p> <ul style="list-style-type: none"> ▪ There must be at least one barcode on the bag. ▪ The optimal solution includes two diagonally offset barcodes on the back. ▪ The barcode should always be placed horizontally and on the tautest part of the bag as possible (e.g. lower third). ▪ Placements at the edges / close to welds should be avoided (see illustration “Positioning not optimal”). <p data-bbox="858 1742 1126 1776">b) Stand-up pouches:</p> <ul style="list-style-type: none"> ▪ A barcode must be placed on the back and on the side. ▪ The optimal solution includes an additional barcode on the back wall as on the base

Tubes	Cans and cartridges
<div style="display: flex; justify-content: space-around;"> <div style="text-align: center;"> <p>Alternative 1:</p>  </div> <div style="text-align: center;"> <p>Alternative 2:</p>  </div> </div> <div style="margin-top: 20px;"> <p> Optimal solution</p> <p> Minimum solution</p> </div>	<p>a) Round cans and cartridges:</p>  <p>b) Flat cans:</p>  <p>c) Cartridges:</p> 
<ul style="list-style-type: none"> ▪ Barcodes are to be positioned away from the flanging on the tube fold. ▪ Fence barcodes may only be applied if the angle between the outer edges is 60 ° or less (see Section 1.3.2). ▪ For an optimal solution, position a second barcode (either as an extension of the first barcode or alternatively in an offset diagonal position). 	<p>a) Round cans:</p> <ul style="list-style-type: none"> ▪ The optimal solution includes an additional barcode positioning on the base. ▪ Fence barcodes may only be applied if the angle between the outer edges is 60 ° or less. ▪ Recommendation for large cans: Two barcodes on the can's side, if possible, equidistant from each other. <p>b) Flat cans:</p> <ul style="list-style-type: none"> ▪ There are two barcodes to be positioned on the sides. ▪ The optimal solution also includes placing a barcode on the base. <p>c) Cartridges</p> <ul style="list-style-type: none"> ▪ A circumferential barcode is to be positioned.

Tab / cardboard slipcase and header	Header
<p>a) Tab / cardboard slipcase</p>  <p>The diagrams show two views of a tab/cardboard slipcase. On the left, the front view shows a light blue 'Pouch' with a white 'Front' label and a grey tab on the right. On the right, the back view shows a light blue 'Pouch' with a white 'Back' label and a black tab on the right. Below these, a diagram of a header shows a pink oval with a white 'Back' label and a black tab on top, and a white 'Front' label on the bottom. A horizontal pink line indicates the fold.</p> <p>a) Header</p>	 <p>The diagrams show two views of a header. On the left, the back view shows a pink header with a white 'Back' label and a black tab on the bottom left. On the right, the front view shows a pink header with a white 'Front' label and a grey tab on the bottom left.</p>
<ul style="list-style-type: none"> ▪ A barcode on the back ▪ For an optimal solution, a barcode on the front side should also be used (exception: header). ▪ The tab can also be used without Euro holes. 	<ul style="list-style-type: none"> ▪ There must be at least one barcode on the back of the hang tag. ▪ For an optimal solution, there should be a long barcode on the back that pulls towards the front.

Hangtag	Flag label
	
<ul style="list-style-type: none"> ▪ There must be at least one barcode on the back of the hang tag. ▪ For an optimal solution, there should be a long barcode on the back that pulls towards the front. 	<ul style="list-style-type: none"> ▪ At least one barcode on the back of the flag label ▪ For an optimal solution, an additional barcode should be placed on the front. ▪ The two sides not described are glued together to the flag label.
Care label	Sew-in woven label
<ul style="list-style-type: none"> ▪ <ul style="list-style-type: none"> Size Care instructions Material composition Care instructions Distributor Made in 	<ul style="list-style-type: none"> ▪ 
<ul style="list-style-type: none"> ▪ A barcode can be placed below. ▪ Its use is obligatory for textile items from Penny 	<ul style="list-style-type: none"> ▪ A barcode can be placed on the front. ▪ A sew-in woven label will be used if no care label is planned. ▪ Its use is obligatory for textile items from Penny

Banderole

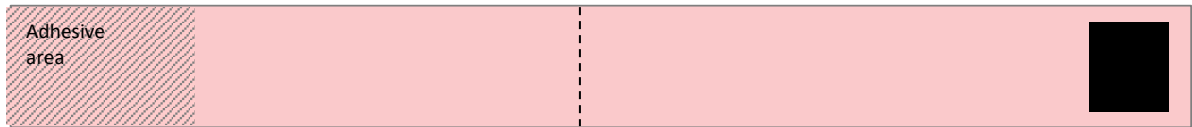

- A barcode is required.
- The barcode covers the adhesive surface.
- To ensure the scanning capability of the barcode, the curvature must not exceed the angle of 60 °.

Inserts

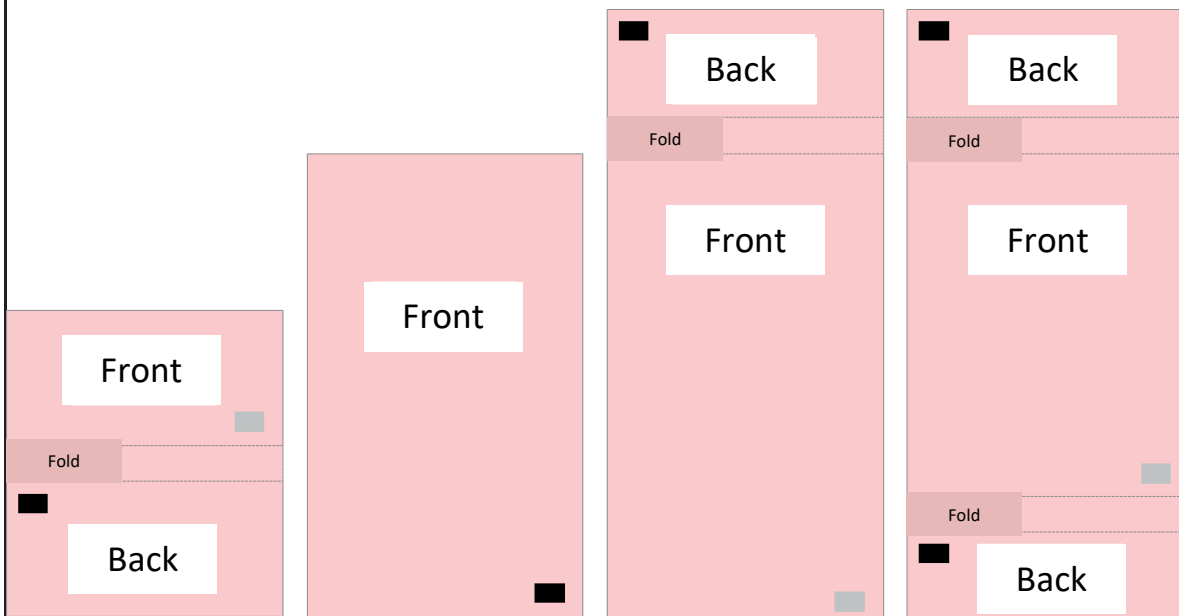

- At least one barcode must be placed on the back (exception: one-sided insert).
- For an optimal solution, an additional barcode should be positioned on the front.

Blister

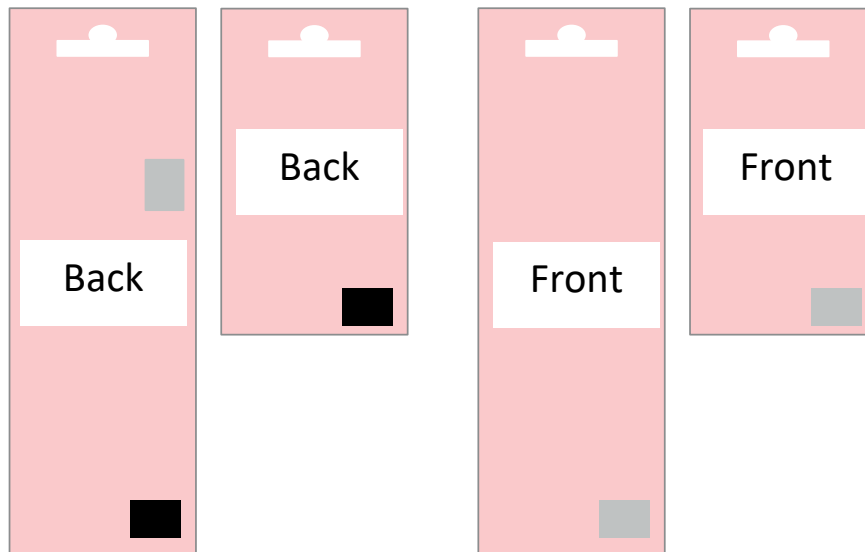

- There must be at least one barcode on the back.
- For the best solution, a barcode should be positioned on the front of the blister.
- Depending on the size of the blister, a second barcode can be used as an option (maximum edge length 40cm, otherwise double scans may occur if there are 2 barcodes on the back).
- The blister can also be used without Euro holes.

Annex 2: Specified goods pursuant to [Implementing Decision 2013/92/EU](#)

The product groups concerned are listed in annex I to the Implementing Decision and include the following CN codes: 2514 00 00, 2515, 2516, 6801 00 00, 6802, 6803 00, 6907 and 7210.

Combined Nomenclature Code	Description	Frequency of plant health checks (%)
<i>Combined Nomenclature Code</i>	<i>Description</i>	<i>Frequency of plant health checks (%)</i>
2514 00 00	<p>Slate, whether or not roughly trimmed or merely cut, by sawing or otherwise, into blocks or slabs of a rectangular (including square) shape</p> <p><i>Slate, whether or not roughly trimmed or merely cut, by sawing or otherwise, into blocks or slabs of a rectangular (including square) shape</i></p>	15
2515	<p>Marble, travertine, ecaussine and other calcareous monumental or building stones of an apparent specific gravity of 2.5 or more, and alabaster, whether or not roughly trimmed or merely cut, by sawing or otherwise, into blocks or slabs of a rectangular (including square) shape</p> <p><i>Marble, travertine, ecaussine and other calcareous monumental or building stones of an apparent specific gravity of 2.5 or more, and alabaster, whether or not roughly trimmed or merely cut, by sawing or otherwise, into blocks or slabs of a rectangular (including square) shape</i></p>	15
2516	<p>Granite, porphyry, basalt, sandstone and other monumental or building stones, whether or not roughly trimmed or merely cut, by sawing or otherwise, into blocks or slabs of a rectangular (including square) shape</p> <p><i>Granite, porphyry, basalt, sandstone and other monumental or building stones, whether or not roughly trimmed or merely cut, by sawing or otherwise, into blocks or slabs of a rectangular (including square) shape</i></p>	15
6801 00 00	<p>Setts, curbstones and flagstones, of natural stone (except slate)</p> <p><i>Setts, curbstones and flagstones, of natural stone (except slate)</i></p>	15
6802	<p>Worked monumental or building stone (except slate) and articles thereof, other than goods of heading 6801 ; mosaic cubes and the like, of natural stone (including slate), whether or not on a backing; artificially coloured granules, chippings and powder, of natural stone (including slate)</p>	15

	<i>Worked monumental or building stone (except slate) and articles thereof, other than goods of heading 6801 ; mosaic cubes and the like, of natural stone (including slate), whether or not on a backing; artificially coloured granules, chippings and powder, of natural stone (including slate)</i>	
6803 00	Worked slate and articles of slate or of agglomerated slate <i>Worked slate and articles of slate or of agglomerated slate</i>	15
6907	Glazed ceramic flags and paving, hearth or wall tiles; glazed ceramic mosaic cubes and the like, whether or not on a backing <i>Glazed ceramic flags and paving, hearth or wall tiles; glazed ceramic mosaic cubes and the like, whether or not on a backing</i>	15
7210	Flat-rolled products of iron or non-alloy steel, of a width of 600mm or more, clad, plated or coated <i>Flat-rolled products of iron or non-alloy steel, of a width of 600mm or more, clad, plated or coated</i>	15

Legal Notice

© REWE Group Buying GmbH
Domstraße 20
50668 Köln

Version 2.0
Valid from 1st August 2021